



omega

Instruction Manual

Ceramic Cooktop

OCC30TZ

Thank you for purchasing an Omega appliance

Tailored for the modern aesthetic and lifestyle of busy people, your new Omega Appliance will make a welcome addition to the family.

Omega caters to style-savvy customers who look for balance between stunning form and clever function. This means a combination of sleek, chic, sophisticated design yet effortless functionality. And we source from the best. The best craftsmanship. The best innovation. From the best international design-houses.

All brought together under an appliance that stands for design-led balance.

Please take the time to read through the following instruction manual to familiarise yourself with the installation, operation requirements and maintenance to ensure optimum performance.

Further Information

For important information about your Omega Appliance such as warranty registration, manuals, features, and specifications please visit omegaappliances.com.au (if you are in Australia) and omegaappliances.co.nz (if you are in New Zealand) or contact our Customer Care team on the below email or phone numbers.

Registering Your Warranty

For peace of mind you can register your warranty at omegaappliances.com.au. Further information on the Warranty can be found at the end of this manual.

Contact Us

Our customer service team is here to help you with any question or concern. Both teams are on call Monday to Friday 9.00am to 5.00pm and of course you can always send an email at your convenience.

Australia Contact Details

Monday to Friday 9.00am – 5.00pm

Email: support@residentiagroup.com.au

Phone: 1300 11 4357

New Zealand Contact Details

Monday to Friday 9.00am – 5.00pm

Email: customercare@monacocorp.co.nz

Phone: 09 415 6000

To stay up to date and find simple and easy recipes, follow us on our socials:

facebook.com/omegaappliances

instagram.com/omegaappliances_au

READ THE INSTRUCTION BOOKLET BEFORE INSTALLING AND USING THE APPLIANCE.

It is important that you retain these instructions, proof of purchase as well as other important documents about this product for future reference.

The manufacturer will not be responsible for any damage to property or to persons caused by incorrect installation or improper use of the appliance.

Due to continual product development, Omega reserves the right to alter specifications and appearances without notice.

Contents

Important Safety Warnings	4
Product Information.....	6
Installation Instructions.....	7
Operating Instructions	8-9
Cleaning and Maintenance	11
Australian & New Zealand Product Warranty Statements of Standard Warranty Conditions	13

Disposal Information

- Most of the packaging materials are recyclable. Please dispose of these materials through your local recycling depot or by placing them into appropriate collection containers.
- If you wish to discard this product, please contact your local authorities and ask for the correct method of disposal.

Important Safety Warnings

IMPORTANT: Read the assembly instruction section and safety precautions of this booklet carefully before removing the contents of this carton.

1. This appliance is not intended for use by persons (including children) with reduced physical, sensory or mental capabilities, or lack of experience or knowledge, unless they have been given supervision or instruction concerning the use of the appliance by a person responsible for their safety. Children should be supervised to ensure that they do not play with the appliance.
2. After removing the packaging, make sure to check if there is any damage to the appliance. If there is any damage (including cracked glass), never attempt to use the appliance and immediately contact your Authorised Service Centre. As packaging materials can be dangerous to children, they need to be collected immediately and put out of reach.
3. In certain circumstances electrical appliances may be a safety hazard. Check the conformity of voltage and power settings, which are specified on the information plate attached to the appliance and/or packaging.
4. Do not place heavy objects in or on these appliances, use for storage or as a cutting surface. This appliance is designed for cooking food only. Use flat based, stable cooking pots only.
5. This appliance is designed for domestic household use only and for the cooking of domestic food products. Use as a commercial appliance will void the warranty. It should not be used in a marine environment or outdoors and must be fully built in. Do not use the appliances until fully installed.
6. This appliance is supplied with a 15-amp plug. The plug has a large earth terminal that will not fit into a common electrical socket. To install the appliance, a special socket is required to be installed by a licensed electrician (if it does not already exist at the point of installation). If the electrical supply cord is damaged, either when being installed or after installation, it must be replaced by the manufacturer, its service centre or similarly qualified persons in order to prevent a hazard.
7. A means for disconnection must be incorporated in the fixed wiring in accordance with the wiring rules.
8. The electrical connection must be accessible after installation. The appliance must be electrically isolated before any maintenance can be performed. Electrical connection must be made as per local wiring rules and regulations.
9. The appliance is not intended to be operated by means of an external timer or separate remote-control system.
10. Ensure that the kitchen is well ventilated or mechanical ventilation is in use while cooking on this appliance.
11. Do not store or use flammable materials or aerosols near the cooktop. Items made from aluminium, plastic or plastic film should also be kept away from the appliance, as they may fuse to the surface.
12. **WARNING** - The appliance will become hot during and directly after use. Do not touch the surface during this time, as it may be hot and can cause burns. To avoid burns, children should be kept away.
13. Cleaning may only be commenced on the appliance once it has cooled down and is turned off. Do not use a steam jet or any other high-pressure cleaning equipment to clean the appliance. Steam cleaner is not be used.
14. When the appliance is not being used, turn the appliance off.
15. Where this appliance is installed in a caravan, it shall NOT be used as a space heater.
16. Do not modify this appliance.
17. Do not use harsh abrasive cleaners or sharp metal scrapers to clean the glass surface as they can scratch the surface, which may result in the glass shattering. Clean the glass using a warm damp cloth (e.g. dishcloth) and dry it with a soft dry tea towel.
18. All cabinetry and materials used in the installation must be able to withstand a minimum temperature of 100°C above the ambient temperature of the room it is in, whilst in use. Certain types of vinyl or laminate kitchen furniture are particularly prone to heat damage or discolouration at temperatures below the guidelines given above. Any damage caused by the appliance being installed without adhering to the temperature limits set out above will be the liability of the owner. To avoid any hazards, limit access to the under-bench section of the cooktop.

omega

Important Safety Warnings

19. The appliance must be installed and put into operation by an authorised technician under the conditions provided by the manufacturer in this manual. The manufacturer cannot be held responsible for any damage that might occur due to faulty installation. Do not install near cooling equipment, dishwashers or clothes dryers.
20. Damage can occur to bench tops if pots and pans are allowed to overlap the bench top. This can result in heat being transferred to the bench top. Ensure that correct sized pots & pans are used. Cast iron and cast aluminium cookware with damaged bases may scratch the cooktop surface if they are dragged across it. Pans should be lifted on and off the appliance surface and not dragged. Cooking zones should not be switched on without cookware placed on it. Cookware should not be empty for any length of time when being used on the appliance.
21. **WARNING:** If the surface is cracked, switch off the appliance to avoid the possibility of electrical shock.
22. Do not leave the appliance while cooking with solid or liquid oils. There may be flaming up in conditions of extreme heating.
23. Never pour water onto the flames occurring from oil. Immediately turn the appliance off and cover the pan with a lid or fire blanket in order to smother the flame.
24. **DANGER OF FIRE:** Do not store items on the cooking surfaces.
25. **CAUTION:** The cooking process has to be supervised. A short term cooking process has to be supervised continuously.
26. **WARNING:** Unattended cooking on a hob with fat or oil can be dangerous and may result in a fire.
27. Means for disconnection must be incorporated in the fixed wiring in accordance with the wiring rules.

Product Information

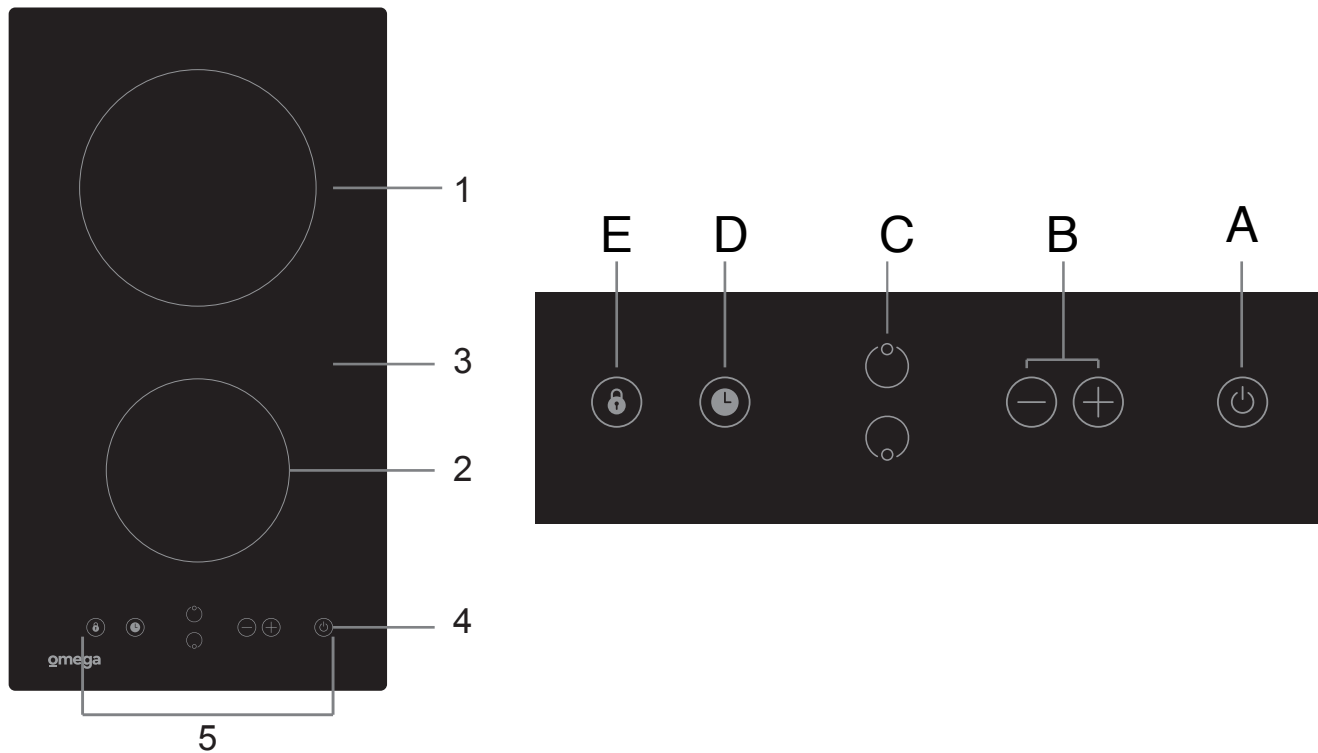

1. 1800W Cooking Zone.
2. 1200W Cooking Zone.
3. Glass Plate.
4. ON/OFF Button.
5. Control Panel.
- A. On/Off Button.
- B. Power/Timer Increase/Decrease Buttons.
- C. Cooking Zone Select Buttons.
- D. Timer Button.
- E. Key Lock Button.

ELECTRICAL DETAILS

Rated Voltage: 220-240Vac 50Hz
 Power Rating: 2700-3300W
 Plug: 15A plug.

This information can be found on the rating plate (identification plate) affixed to the underside of the appliance.

Relevant Sizes:	WIDTH (mm)	LENGTH (mm)	HEIGHT (mm)
Cooktop Size	288	520	55
Cut-out Size	268	490	-

Installation Instructions

Cut out the work surface according to the sizes shown below.

A minimum of 50mm must be left between the edge of the hole and any edge of the work surface. The work surface must be at least 30mm thick. Take care that the material of the work surface is heat resistant to at least 100°C to avoid any damage to the work surface.

- A – 268 to 272mm.
- B – 490 to 494mm.
- C, D, E, F – 50mm minimum.

Make sure the ceramic cooker hob is well ventilated and the air inlet and outlet are not blocked. Follow the following dimensions:

Note: The safety distance between the cooktop and the cupboard above the cooktop should be at least 760mm, and between the cooktop and rangehood must be a minimum of 650mm.



- A – 760mm minimum to overhead cupboard, 650mm minimum to range hood.
- B – 50mm minimum.
- C – 30mm minimum.
- D – Air intake.
- E – 10mm x length of cooktop air exit.

Place the cooktop on a flat clean surface (for example part of the carton). Loosely fit the rear 2 mounting brackets. Slide the cooktop into the hole and fit the front 2 mounting brackets. Adjust the position of the cooktop so it is central within the hole and tighten all brackets.

Electrical Connection

Installation is only permitted by a licensed electrician, and carried out according to instructions provided by the manufacturer. Incorrect installation might cause harm and damage, for which the manufacturer accepts no responsibility.

Before carrying out the connection to the power supply, the voltage rating of the appliance (stamped on the appliance identification plate) must be checked for correspondence to the available mains supply voltage, and the mains electric wiring should be capable of handling the oven's power rating (also indicated on the identification plate). After having installed the appliance, the switched outlet must always be in an accessible position.

The cooktops are to be connected to a single phase 220-240Vac 50 Hz supply and earthed via the 15A plug. The mains terminal is on the underside of the cooktop (this should be fully closed after installation). During installation, an all pole disconnecter should be included inside the supply circuit with a contact opening of at least 3mm. The power supply cord must not touch against any hot surfaces and must be placed so that its temperature does not exceed 75 °C at any point along its length. The electrical safety of this appliance can only be guaranteed if the oven is correctly and efficiently earthed. The manufacturer declines all responsibility for damage resulting from an installation which has not been earthed correctly.

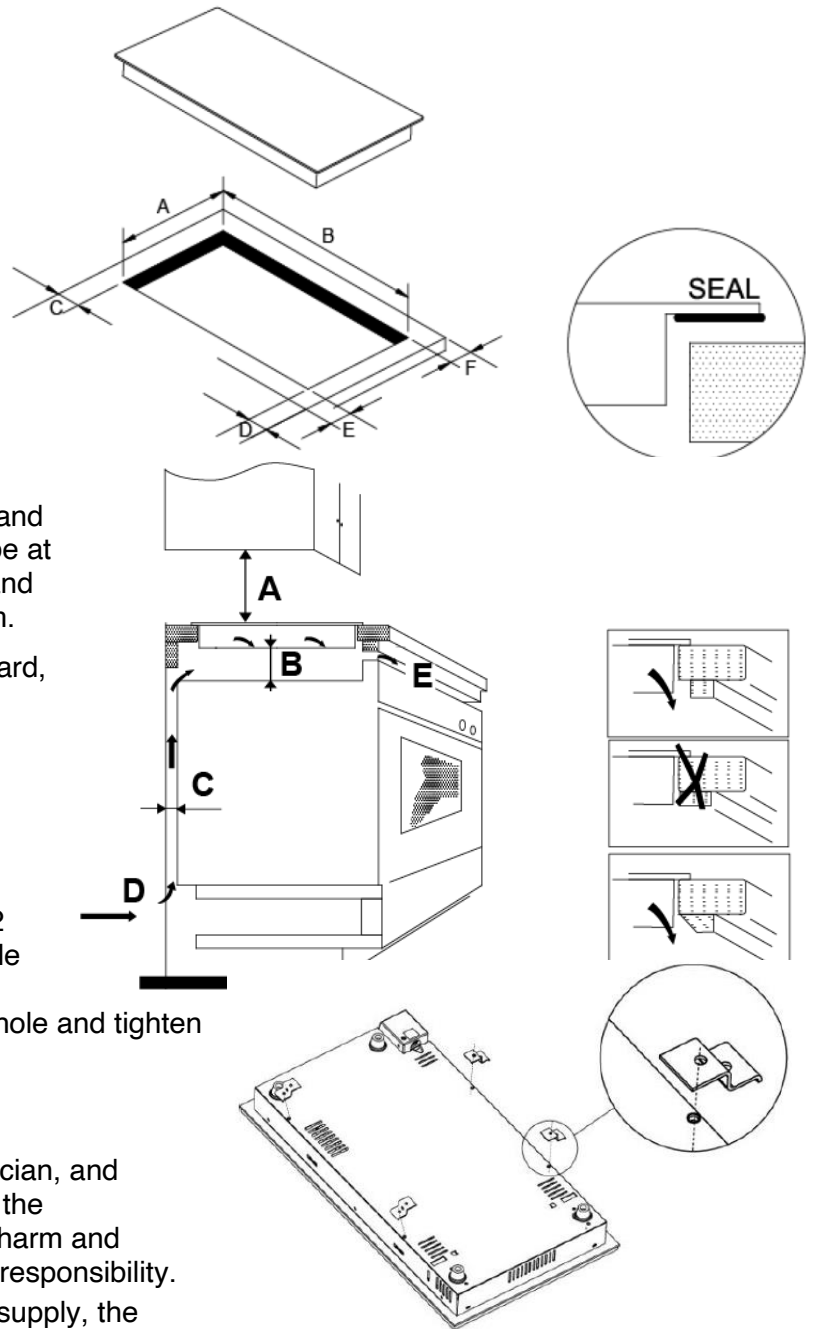

Operating Instructions

TOUCH CONTROLS:

- The controls respond to touch, so you don't need to apply any pressure.
- Use the ball of your finger, not its tip.
- You will hear a beep each time a touch is registered.
- Make sure the controls are always clean, dry, and that there is no object (e.g. a utensil or a cloth) covering them. Even a thin film of water may make the controls difficult to operate.

CHOOSING THE CORRECT COOKWARE:

Cookware with rough bases should not be used as they can scratch the glass ceramic surface. The base of the good cookware should be as thick and flat as possible. Before use, make sure that cookware bases are clean and dry.

Always place the cookware on the cooking zone before it is switched on. If possible, always place the lids on the cookware. The base of any cookware used must not be smaller or larger than the cooking zones; they should be the proper size as indicated below, so as not to waste energy.

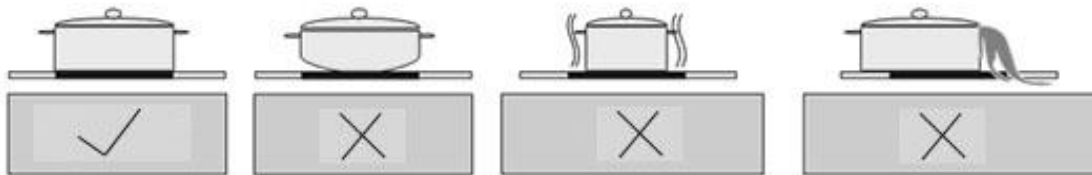

Safety Features

There are a number of safety features built into the cooktop.

Over-Temp Protection

The cooking zones are equipped with sensors to monitor the temperatures at the cooking zone. If the temperature becomes excessive the cooker will turn off.

Residual Heat Warning

When a cooking zone has run for a period of time, there will be some residual heat left once the cooking zone is turned off. If the temperature is too high, a "H" will be shown on the cooking zone display until the temperature decreases to a safe level.

Default Cooking Zone Working Times

In case of a cooking zone being left on accidentally, each cooking zone has a maximum working time dependent on the power setting. If the time is exceeded the cooktop will turn off.

Power Level	1	2	3	4	5	6	7	8	9
Default Time (hr)	8	8	8	4	4	4	2	2	2

Operating Instructions

Press the ON/OFF  button. All the displays will show “-”

Place a suitable pan on the cooking zone that you wish to use.

- Make sure the bottom of the pan and the surface of the cooking zone is clean and dry.

Press the cooking zone button. The current power level will be displayed (to the right of the button).

Adjust the power setting by pressing the increase/decrease buttons (0-9).

- If you don't choose a power setting within 1 minute, the ceramic hob will automatically switch off. You will need to start again.
- You can modify the power setting at any time during cooking.

Once cooking has finished, press the cooking zone button for the cooking zone to be turned off.

Adjust the power setting down to “0” using the decrease button, or by pressing both the decrease and increase buttons simultaneously.

Turn the whole cooktop off by pressing the ON/OFF  button. If a cooking zone is hot after the cooking zone has been turned off, the display will show “H” until the cooking zone cools down.

Key Lock

The key lock is used to disable the control buttons (except the ON/OFF button) to stop accidental changes to settings.

To lock the appliance, first turn on the power using the ON/OFF control button, and adjust the cooking zone settings. Press the key lock button. The timer display will change to “LO”, indicating the key lock is active.

To disable the key lock function, first make sure the cooktop is on. Press the key lock button for a few seconds and the buttons will become responsive again.

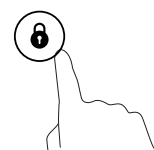
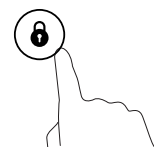
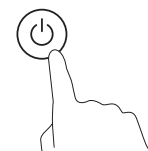
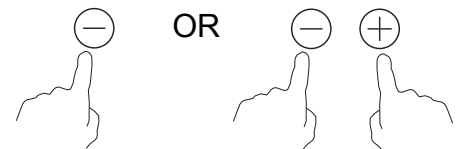
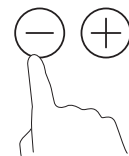
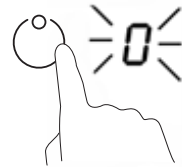
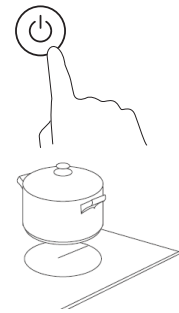

Operating Instructions

Timer Functions

There are two different timer functions. The first is the Minute Minder. This is a timer that can be set up as a reminder (add extra water, add spices etc) but does not affect the cooking zones in any way. The second is a cooking zone timer which can be set to turn off a cooking zone after a period of time.

To set up a Minute Minder timer function, first make sure the cooktop has been turned on (a cooking zone does not need to be active).

Press the timer button and the timer display will flash the current setting.

Adjust the Minute Minder time by pressing the increase & decrease buttons. The time will be shown on the timer display.

Once the Minute Minder time has been set, it will start to count down (in minute increments). The timer display will flash for 5 seconds and then will show the remaining time.

To adjust the time at any point, repeat the steps above. The timer can be cancelled by reducing the time to "0", either by pressing the decrease button, or both the decrease and increase buttons simultaneously.

When the Minute Minder has finished, the buzzer will sound for 30 seconds and the timer display will show "--".

NOTE: The Minute Minder can be set for a maximum time of 99 minutes.

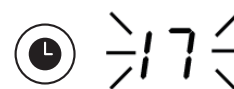
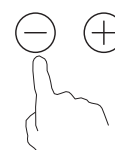

To set up a timer function on a cooking zone, first turn on the cooktop and select the power level. Press the cooking zone select button for the cooking zone to have the timer function.

Press the timer button and the timer display will show "10" for a pre-set 10 minute timer.

Adjust the time by pressing the increase & decrease buttons. The time will be shown on the timer display.

Once the time has been set, it will start to count down (in minute increments). The timer display will flash for 5 seconds and then will show the remaining time.

To adjust the time at any point, repeat the steps above. The timer can be cancelled by reducing the time to "0", either by pressing the decrease button, or both the decrease and increase buttons simultaneously.

When the time has finished, the buzzer will sound for 30 seconds and the timer display will show "--". The cooking zone will also turn off.

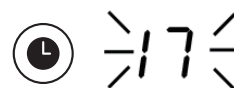
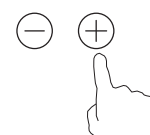

NOTE: When a timer function is allocated to a cooking zone, the decimal point of the cooking zone display will flash.

To set up a second timer function at the same time, repeat the steps above. The remaining time for either cooktop can be checked by selecting the cooking zone and then pressing the timer button. The decimal point of the cooking zone with the shortest time left will flash while all other cooking zones with timers set will have their decimal point lit. When one timer finishes and the cooking zone turns off, the decimal point on the cooking zone with the next shortest timer will begin to flash.



Cleaning and Maintenance

NOTE: Cleaning and maintenance operations must only be carried out when the cooktop is cool (all residual heat indicators are off).

The appliance should be disconnected from the power outlet or turned off at your isolation switch before commencing any cleaning process.

Do not use plastic, plastic coated or aluminium cooking equipment on this appliance.

Cleaning the Cooktop

Before cleaning the cooktop, first isolate the cooktop from the power. Once done, ensure that there is no residual heat stored in the appliance. Vitro-ceramic glass is very resistant to high temperature and overheating. If there is residual heat stored in the appliance, the related residual heat icon will be on. To avoid burns, let the appliance cool down.

- Remove all spilled food and fat with a clean, damp, warm, slightly soapy dishcloth. Rinse cloth and wipe cooktop again until clean, then wipe the cooktop dry with a clean tea towel or dry, soft cloth.
- If aluminium foil or plastic items are accidentally melted onto the vitro-ceramic surface, they should be immediately removed from the hot cooking area with a scraper specifically designed for vitro-ceramic glass. This will avoid any possible damage to the surface. This also applies to sugar or food containing sugar that may be spilled on the cooktop.
- In the event of other food melted onto the cooktop surface, remove the dirt when the appliance has cooled down. Use cleaner for glass ceramic or stainless steel when cleaning the surface.
- Do not use abrasive sponges to clean the vitro-ceramic surface. These materials may damage the surface.
- Do not use chemical detergents, sprays or spot removers on the vitro-ceramic surface. These materials may cause fire or the vitro-ceramic colour to fade. Clean with a damp, warm, slightly soapy dishcloth.
- **WARNING:** Using cookware that is too large can cause discolouration or damage to the cooktop surface around the heat zones, which is NOT covered under warranty.

Troubleshooting

Problem	Possible causes	What to do
The cooktop cannot be turned on.	No power.	Make sure the cooktop is connected to the power supply and that it is switched on. Check whether there is a power outage in your home or area. If you've checked everything and the problem persists, call a qualified technician.
The touch controls are unresponsive.	The controls are locked.	Unlock the controls. See section 'Operating Instructions' for direction.
The touch controls are difficult to operate.	There may be a slight film of water over the controls or you may be using the tip of your finger when touching the controls.	Make sure the touch control area is dry and use the ball of your finger when pressing the controls.
The glass is being scratched.	Rough-edged cookware.	Use cookware with flat and smooth bases.
	Unsuitable, abrasive scourer or cleaning products being used.	Use only recommended cleaners.
Some pans make crackling or clicking noises.	This may be caused by the construction of your cookware (layers of different metals vibrating differently).	This is normal for cookware and does not indicate a fault.

Troubleshooting

Problem	Possible causes	What to do
The cooktop cannot be turned on.	No power.	Make sure the cooktop is connected to the power supply and that it is switched on. Check whether there is a power outage in your home or area. If you've checked everything and the problem persists, call a qualified technician.
The touch controls are unresponsive.	The controls are locked.	Unlock the controls. See section 'Operating Instructions' for direction.
The touch controls are difficult to operate.	There may be a slight film of water over the controls or you may be using the tip of your finger when touching the controls.	Make sure the touch control area is dry and use the ball of your finger when pressing the controls.
The glass is being scratched.	Rough-edged cookware.	Use cookware with flat and smooth bases.
	Unsuitable, abrasive scourer or cleaning products being used.	Use only recommended cleaners.
Some pans make crackling or clicking noises.	This may be caused by the construction of your cookware (layers of different metals vibrating differently).	This is normal for cookware and does not indicate a fault.

Warranty

WARRANTY TERMS AND CONDITIONS COOKTOPS

This document sets out the terms and conditions of the product warranties for Residentia Group Appliances. It is an important document. Please keep it with your proof of purchase documents in a safe place for future reference should you require service for your Appliance.

1. IN THIS WARRANTY

- (a) 'acceptable quality' as referred to in clause 10 of this warranty has the same meaning referred to in the ACL;
 - (b) 'ACL' means Trade Practices Amendment (Australian Consumer Law) Act (No.2) 2010;
 - (c) 'Appliance' means any Residentia Group product purchased by you accompanied by this document;
 - (d) 'ASR' means Residentia Group authorised service representative;
 - (e) 'Residentia Group' means Residentia Group Pty Ltd of 165 Barkly Ave, Burnley VIC 3121, ACN 600 546 656 in respect of Appliances purchased in Australia;
 - (f) 'major failure' as referred to in clause 10 of this warranty has the same meaning referred to in the ACL and includes a situation when an Appliance cannot be repaired or it is uneconomic for Residentia Group, at its discretion, to repair an Appliance during the Warranty Period;
 - (g) 'Warranty Period' means:
 - (i) where the Appliance is used for personal, domestic or household use (i.e. normal single family use) as set out in the instruction manual, the Appliance is warranted against manufacturing defects for 24 months, following the date of original purchase of the Appliance;
 - (h) 'you' means the purchaser of the Appliance not having purchased the Appliance for re-sale, and 'your' has a corresponding meaning.
2. This warranty only applies to Appliances purchased and used in Australia and is in addition to (and does not exclude, restrict, or modify in any way) any non-excludable statutory warranties in Australia.
3. During the Warranty Period Residentia Group or its ASR will, at no extra charge if your Appliance is readily accessible for service, without special equipment and subject to these terms and conditions, repair or replace any parts which it considers to be defective. Residentia Group or its ASR may use remanufactured parts to repair your Appliance. You agree that any replaced Appliances or parts become the property of Residentia Group. This warranty does not apply to light globes, batteries, filters, seals or similar perishable parts.
4. Parts and Appliances not supplied by Residentia Group are not covered by this warranty.
5. You will bear the cost of transportation, travel and delivery of the Appliance to and from Residentia Group or its ASR. If you reside outside of the service area, you will bear the cost of:
 - (a) travel of an authorised representative;
 - (b) transportation and delivery of the Appliance to and from Residentia Group or its ASR, in all instances, unless the Appliance is transported by Residentia Group or its ASR, the Appliance is transported at the owner's cost and risk while in transit to and from Residentia Group or its ASR.
6. Proof of purchase is required before you can make a claim under this warranty.
7. You may not make a claim under this warranty unless the defect claimed is due to faulty or defective parts or workmanship. Residentia Group is not liable in the following situations (which are not exhaustive):
 - (a) the Appliance is damaged by:
 - (i) accident
 - (ii) misuse or abuse, including failure to properly maintain or service
 - (iii) normal wear and tear
 - (iv) power surges, electrical storm damage or incorrect power supply
 - (v) incomplete or improper installation
 - (vi) incorrect, improper or inappropriate operation
 - (vii) insect or vermin infestation
 - (viii) failure to comply with any additional instructions supplied with the Appliance;

— THIS WARRANTY IS VALID IN AUSTRALIA ONLY —

Warranty

- (b) the Appliance is modified without authority from Residentia Group in writing;
 - (c) the Appliance's serial number or warranty seal has been removed or defaced;
 - (d) the Appliance was serviced or repaired by anyone other than Residentia Group, an authorised repairer or ASR.
8. This warranty, the contract to which it relates and the relationship between you and Residentia Group are governed by the law applicable where the Appliance was purchased.
9. To the extent permitted by law, Residentia Group excludes all warranties and liabilities (other than as contained in this document) including liability for any loss or damage whether direct or indirect arising from your purchase, use or non use of the Appliance.
10. For Appliances and services provided by Residentia Group in Australia, the Appliances come with a guarantee by Residentia Group that cannot be excluded under the Australian Consumer Law. You are entitled to a replacement or refund for a major failure and for compensation for any other reasonably foreseeable loss or damage. You are also entitled to have the Appliance repaired or replaced if the Appliance fails to be of acceptable quality and the failure does not amount to a major failure. The benefits to you given by this warranty are in addition to your other rights and remedies under a law in relation to the Appliances or services to which the warranty relates.
11. At all times during the Warranty Period, Residentia Group shall, at its discretion, determine whether repair, replacement or refund will apply if an Appliance has a valid warranty claim applicable to it.
12. Missing parts are not covered by warranty. Residentia Group reserves the right to assess each request for missing parts in a case by case basis. Any parts that are not reported missing in the first week after purchase will not provide free of charge.
13. To enquire about claiming under this warranty, please follow these steps:
- (a) carefully check the operating instructions, user manual and the terms of this warranty;
 - (b) have the model and serial number of the Appliance available;
 - (c) have the proof of purchase (e.g. an invoice) available;
 - (d) telephone the numbers shown below.
14. You accept that if you make a warranty claim, Residentia Group and its ASR may exchange information in relation to you to enable Residentia Group to meet its obligations under this warranty.

IMPORTANT

Before calling for service, please ensure that the steps in point 13 have been followed.

CONTACT SERVICE

→ Service: 1300 11 HELP (4357)

The Australian Consumer Law requires the inclusion of the following statement with this warranty:

Our goods come with guarantees that cannot be excluded under the Australian Consumer Law. You are entitled to a replacement or refund for a major failure and for compensation for any other reasonably foreseeable loss or damage. You are also entitled to have the goods repaired or replaced if the goods fail to be of acceptable quality and the failure does not amount to a major failure.

— THIS WARRANTY IS VALID IN AUSTRALIA ONLY —

