

The Omega logo is rendered in a bold, lowercase, sans-serif font. The letter 'o' is distinguished by a horizontal line passing through its center. The logo is positioned in the upper left quadrant of the page, set against a light gray circular background element that partially overlaps the white page.

**omega**

Instruction Manual

Induction Cooktop

---

Model OCI64

# Thank you for purchasing an Omega appliance

Tailored for the modern aesthetic and lifestyle of busy people, your new Omega Appliance will make a welcome addition to the family.

Omega caters to style-savvy customers who look for balance between stunning form and clever function. This means a combination of sleek, chic, sophisticated design yet effortless functionality. And we source from the best. The best craftsmanship. The best innovation. From the best international design-houses.

All brought together under an appliance that stands for design-led balance.

Please take the time to read through the following instruction manual to familiarise yourself with the installation, operation requirements and maintenance to ensure optimum performance.

## Further Information

For important information about your Omega Appliance such as warranty registration, manuals, features, and specifications please visit [omegaappliances.com.au](http://omegaappliances.com.au) (if you are in Australia) and [omegaappliances.co.nz](http://omegaappliances.co.nz) (if you are in New Zealand) or contact our Customer Care team on the below email or phone numbers.

## Registering Your Warranty

For peace of mind you can register your warranty at [omegaappliances.com.au](http://omegaappliances.com.au). Further information on the Warranty can be found at the end of this manual.

## Contact Us

Our customer service team is here to help you with any question or concern. Both teams are on call Monday to Friday 8.30am to 5.00pm and of course you can always send an email at your convenience.

### Australia Contact Details

Monday to Friday 8.30am – 5.00pm  
Email: [customercare@omegaappliances.com.au](mailto:customercare@omegaappliances.com.au)  
Phone: 1300 739 033

### New Zealand Contact Details

Monday to Friday 8.30am – 5.00pm  
Email: [customercare@monacocorp.co.nz](mailto:customercare@monacocorp.co.nz)  
Phone: 09 415 6000

To stay up to date and find simple and easy recipes, follow us on our socials:

[facebook.com/omegaappliances](https://facebook.com/omegaappliances)  
[instagram.com/omegaappliances\\_au](https://instagram.com/omegaappliances_au)

## READ THE INSTRUCTION BOOKLET BEFORE INSTALLING AND USING THE APPLIANCE.

It is important that you retain these instructions, proof of purchase as well as other important documents about this product for future reference.

The manufacturer will not be responsible for any damage to property or to persons caused by incorrect installation or improper use of the appliance.

*Due to continual product development, Omega reserves the right to alter specifications and appearances without notice.*

## Contents

---

Important Safety Warnings .....	4
Appliance Details .....	6
Electrical Connections .....	7
Installation Instruction .....	8
Operating Instruction .....	11
Cleaning and Maintenance .....	15
Australian & New Zealand Product Warranty Statements of Standard Warranty Conditions .....	16

## Disposal Information

---

- Most of the packaging materials are recyclable. Please dispose of these materials through your local recycling depot or by placing them into appropriate collection containers.
- If you wish to discard this product, please contact your local authorities and ask for the correct method of disposal.

## Important Safety Warnings

---

**IMPORTANT:** Read the assembly instruction section and safety precautions of this booklet carefully before removing the contents of this carton.

1. This appliance is not intended for use by persons (including children) with reduced physical, sensory or mental capabilities, or lack of experience or knowledge, unless they have been given supervision or instruction concerning the use of the appliance by a person responsible for their safety. Children should be supervised to ensure that they do not play with the appliance.
2. After removing the packaging, make sure to check if there is any damage to the appliance. If there is any damage, never attempt to install the appliance and immediately contact your retailer. As packaging materials can be dangerous to children, they need to be collected immediately and put out of reach.
3. In certain circumstances electrical appliances may be a safety hazard. Check the conformity of voltage and power settings, which are specified on the information plate attached to the appliance and/or packaging, with the usage conditions available.
4. Do not place heavy objects in or on these appliances, use for storage or as a cutting surface as sharp edges can damage the surface. This appliance is designed for cooking food only. Use flat based, stable, inductive cooking rated cooking vessels only.
5. This appliance is designed for domestic household use only and for the cooking of domestic food products. Use as a commercial appliance will void the warranty. It should not be used in a marine environment or outdoors and must be fully built in. Do not use the appliances until fully installed.
6. Means for disconnection with a suitable - isolating switch must be incorporated in the fixed wiring in accordance with the wiring rules.
7. The appliance is not intended to be operated by means of an external timer or separate remote-control system.
8. Electrical connection must be made as per local wiring rules and regulations. Do not disconnect the appliance with wet hands or bare feet, and do not disconnect the power cord with extreme force.
9. Ensure that the kitchen is well ventilated or mechanical ventilation is in use while cooking on this appliance.
10. Do not store or use flammable materials or aerosols near the cooktop. Items made from aluminium, plastic, plastic film & sugar-based foods should also be kept away from the appliance, as they may fuse to the surface.
11. **WARNING** – The surface temperature of this appliance exceeds 95°C. To avoid a hazard, under bench access must be restricted. A board must be installed underneath the cooktop. Heat from the underside of the unit will be expelled by inbuilt fans – do not block.
12. **WARNING** - The cooktop will become hot during and directly after use. Do not touch the surface during this time, as it may be hot and can cause burns. To avoid burns, children should be kept away.
13. Cleaning may only be commenced on the appliance once it has cooled down and is turned off. Failure to clean properly can damage the unit. Do not use a steam clean, steam jet or any other high-pressure cleaning equipment to clean the appliance.
14. When the appliance is not being used, turn the appliance off.
15. Do not modify this appliance.
16. Do not use harsh abrasive cleaners or sharp metal scrapers to clean the glass surface as they can scratch the surface, which may result in the glass shattering. Clean the glass using a warm damp cloth (e.g. dishcloth) and dry it with a soft dry tea towel.

## Important Safety Warnings

---

17. All cabinetry and materials used in the installation must be able to withstand a minimum temperature of 50°C above the ambient temperature of the room it is located in, whilst in use. Certain types of vinyl or laminate kitchen furniture are particularly prone to heat damage or discolouration at temperatures below the guidelines given above. Any damage caused by the appliance being installed without adhering to the temperature limits set out above will be the liability of the owner. To avoid any hazards, limit access to the under-bench section of the cooktop.
18. Damage can occur to bench tops if pots and pans are allowed to overlap the bench top. This can result in heat being transferred to the bench top. Ensure that correct sized pots & pans are used. Pans should be lifted on and off the cooktop surface and not dragged. Cooking zones should not be switched on without cookware placed on it. Do not place empty cookware onto the cooking zones when in use.
19. If any cracking is noticed on the cooktop, turn the appliance off immediately and call your Omega Service Centre.
20. Do not leave the cooktop while cooking with solid or liquid oils. There may be flaming up in conditions of extreme heating. Never pour water onto the flames occurring from oil. Immediately turn the cooktop off and cover the pan with a lid or fire blanket in order to smother the flame.
21. Users with pacemakers should keep their upper body at least 30cm away from any operational inductive cooking zone. If in doubt, please consult your doctor before use.
22. Do not place metal objects such as spoons or pan lids onto the cooktop as they may become hot or cause damage to the surface.
23. A small amount of noise will sometimes be heard as elements turn on & off during operation. This is normal & not a fault.
24. **WARNING:** If the surface is cracked, switch off the appliance to avoid the possibility of electric shock.
25. Metallic objects such as knives, forks, spoons and lids should not be placed on the hob surface since they can get hot.
26. **Danger of fire:** Do not store items on the cooking surfaces.
27. **CAUTION:** The cooking process has to be supervised. A short term cooking process has to be supervised continuously.
28. **WARNING:** Unattended cooking on a hob with fat or oil can be dangerous and may result in a fire.
29. If the supply cord is damaged, it must be replaced by the manufacturer, its Authorised Service Centre or a similarly qualified person in order to avoid a hazard.
30. After having installed the appliance, the switched outlet must always be in an accessible position.

## Appliance Details

---

### ELECTRICAL DETAILS:

#### COOKTOP:

Rated Voltage: Single phase 220-240Vac 50Hz,  
7400W

COOKTOP – Directly wired to mains supply

This information can be found on the rating plate (identification plate) affixed to the underside of the appliance.

#### SIZES:

Relevant Sizes:	LENGTH (mm)	WIDTH (mm)	HEIGHT (mm)
Cooktop Size	590	520	53
Cut-out Size	560	490	-

**Due to continual product development, Omega reserves the right to alter specifications or appearances without notice.**

# Electrical Connections



## LOCAL AUTHORITY REQUIREMENTS

Installation is only permitted by a licensed electrician, and carried out according to instructions provided by the manufacturer. Incorrect installation might cause harm and damage, for which the manufacturer accepts no responsibility.

## ELECTRICAL INSTALLATION

Before carrying out the connection to the power supply, the voltage rating of the appliance (stamped on the appliance identification plate) must be checked for correspondence to the available mains supply voltage, and the mains electric wiring should be capable of handling the oven's power rating (also indicated on the identification plate). If you have any doubts, call in a qualified technician.

**NOTE:** For connections to the mains power supply, never use adapters, reductions or multiple power points as these may overheat and catch fire. Do not install separate timers.

After having installed the appliance, the switched outlet must always be in an accessible position. The electrical safety of this appliance can only be guaranteed if the cooktop is correctly and efficiently earthed, always ensure that the earthing is efficient; if you have any doubts call in a licensed electrician to check the system. The manufacturer declines all responsibility for damage resulting from an installation which has not been correctly earthed.

**WARNING:** If any damage occurs to the power cable during or after installation, it must be replaced immediately by a licensed electrician with a replacement cable from your Service Centre.

The mains terminal block is located on the underside of the cooktop and the terminals are accessible by removing the terminal block cover by removing the cover screw. Connect the appliance as shown in the diagram to the right.

The appliance is designed for fixed connection to the mains. The power supply cord must not touch against any hot surfaces and must be placed so that its temperature does not exceed 75 °C at any point along its length.

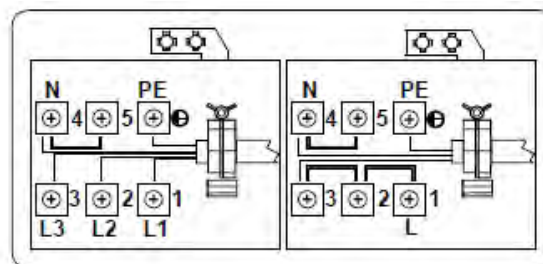

- \* This appliance must be earthed.
- \* For this connection a power lead of wire type H05VV-F should be used.

## Installation Instruction



The adjacent furniture must be able to withstand a minimum temperature rise of 50°C above the ambient temperature of the room it is located in, during periods of use. The power supply to the appliance must be cut off before any adjustments or maintenance work is done on it.

### PREPARATION FOR INSTALLATION AND USE

Manufactured with best quality parts and materials, this modern, functional and practical cooktop will meet your needs in all respects. Make sure to read the manual to obtain successful results so as not to experience any problems in the future. The information given below contains rules that are necessary for correct positioning and service operations. They should be read without fail, especially by the technician who will position the appliance.

### CHOOSING A LOCATION FOR THE APPLIANCE

There are several points to pay attention to when choosing a location for your cooktop. Make sure to take into account our recommendations below in order to prevent any problems and dangerous situations, which might occur later!

When choosing a location for the cooktop, attention should be paid that there are no flammable or combustible materials in the close vicinity, such as curtains, oil, cloth etc. which quickly catch fire.

Required changes to wall cabinets and exhaust fans above a built-in cooktop as well as minimum heights from the oven board are shown in Figure 1. Accordingly, the exhaust fan should be at a minimum height of 65 cm from the cooktop. If there is no exhaust fan the height should not be less than 70 cm.



Figure 1



# Installation Instruction

## INSTALLATION OF BUILT IN COOKTOP

In order to prevent leakage of any liquids on the counter, a special sealing tape is supplied together with your cooktop. Apply this seal around the bottom edge of the cooktop (see below). The brackets are installed to hold the cooktop in place.

Cut out a hole in the bench top as shown below. Place the cooktop (controls to the front) in the hole and fix in position using the brackets.

These induction cooktops are fitted with cooling fans that draw fresh air from the rear of the unit and expel the warmed air through vents at the front. When installing your cooktop, the following ventilation requirements are essential:

- 4mm ventilation cut-out below the benchtop. The minimum length should be the same as the cooktop.
- 10mm ventilation cut-out in the base of the cabinet. Minimum length is the same as the cooktop.
- 20mm gap behind oven or drawers.
- 20mm gap between the cooktop base and the oven/cabinet top/drawer.
- Do not allow these gaps to be blocked at any time.

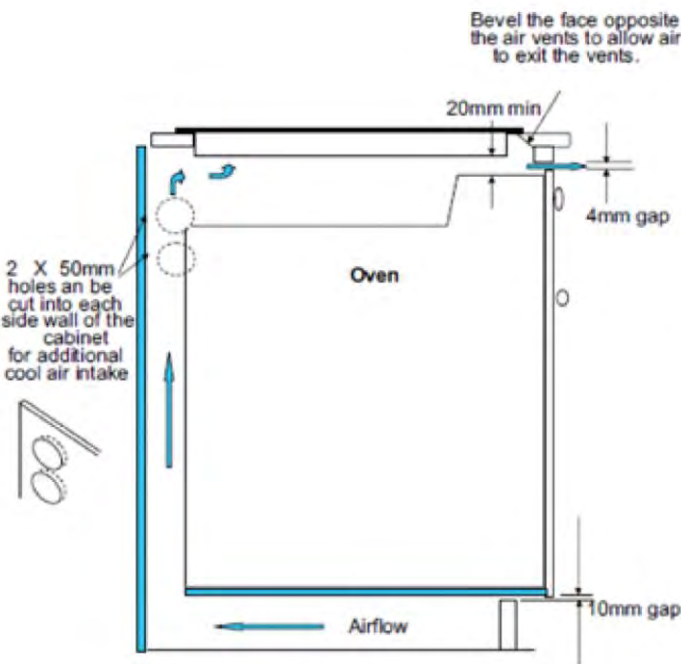
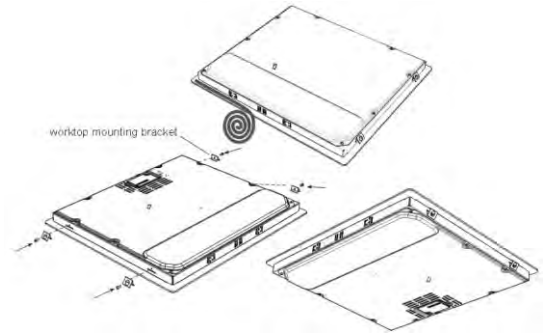

Minimum clearances and ventilation requirements for cooktops installed above an oven

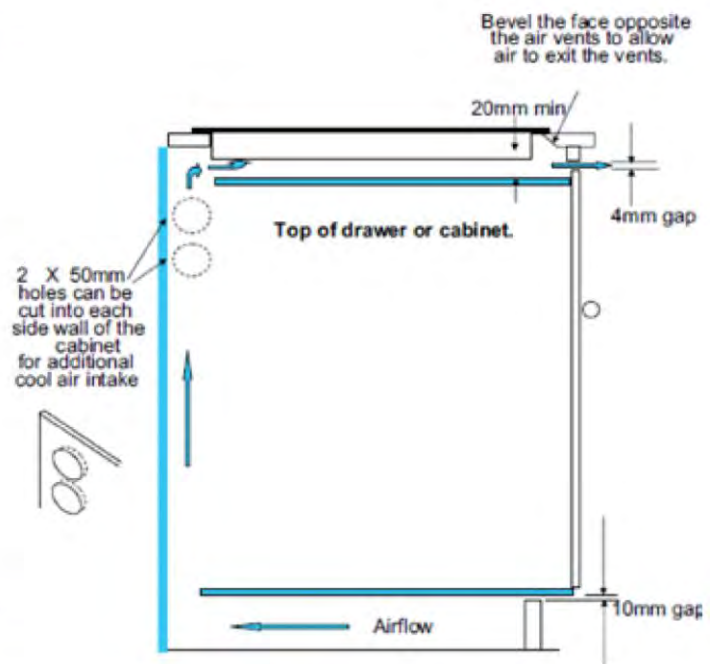

Minimum clearances and ventilation requirements for cooktops installed above a cabinet or drawers

### WARNING:

This product needs to be adequately ventilated to operate properly and ensure a long working life. Please see diagrams.

## Installation Instruction

---

- The bottom of the cooktop reaches temperatures above 95°C. The worktop and furniture surrounding the appliance must be made of materials resistant to temperatures above 100°C.
- The appliance should not be installed directly above a dishwasher, fridge, freezer, washing machine or clothes dryer.
- If the base of the appliance is accessible by hand, a barrier made from a suitable material must be fitted below the base of the appliance, ensuring that there is no access to the base of the appliance.
- If the hob is installed above an oven, the oven should have a cooling fan.
- Make sure that the induction hob is well ventilated and the air inlet and outlet are not blocked.

# Operating Instruction

The basic layout of the induction cooktop is shown in the diagram below.

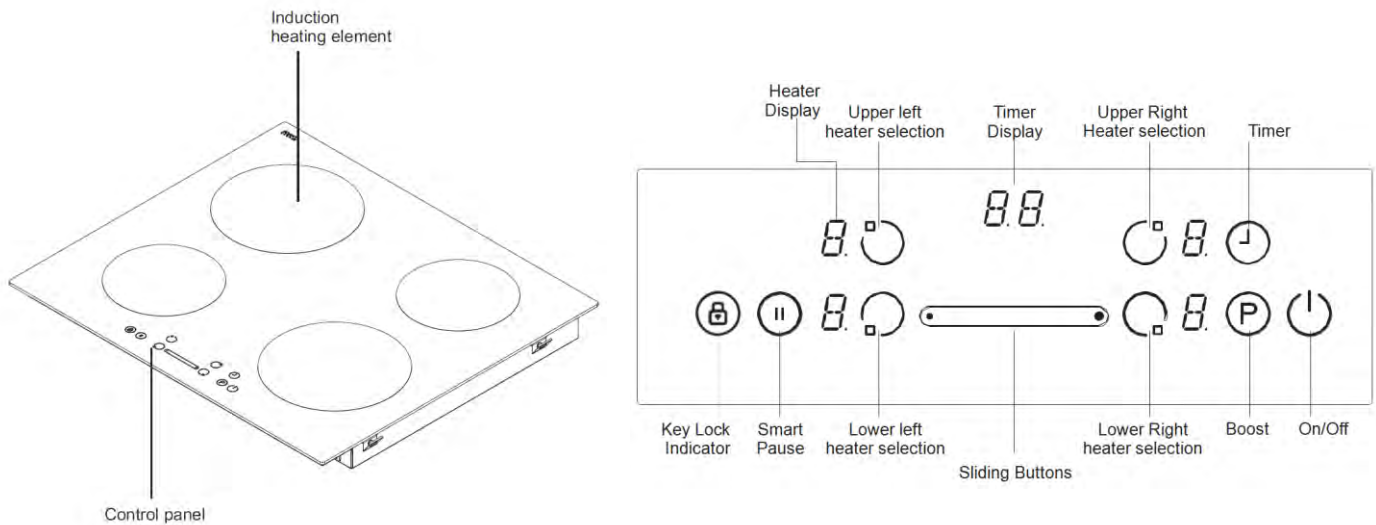

The induction cooktop appliance is operated by touching buttons, with the functions confirmed by LED displays and acoustic signals.

## Turning On and Turning Off the Cooktop Appliance

**NOTE:** Do not operate the cooktop without first placing a suitably sized cooking vessel containing food on the appropriate cooking zone. Missing or incorrectly sized cookware will cause the “U” fault to be displayed on the Heat level display (cooking zone off). Turn off the cooking zone or replace cookware to continue cooking.

If the appliance is in *Stand-By-Mode*, it is put into *Operating-Mode* by pressing the *On/Off* button for at least 1 second. A beep signal indicates the successful operation acoustically.

On all Heat Level Displays a ‘0’ will appear and all *Decimal Points* of the Heat Level displays will flash (1 second on, 1 second off).

If there is no operation within 20 seconds, all the Heat Level Displays will automatically turn off. If the displays are turned off, the hotplates will be re-set into *Stand-By-Mode*.

If *On/Off* is pressed for more than 2 seconds (in *Operating-Mode*), the appliance is switched off and is set into the *Stand-By-Mode* again. The appliance can be turned off by pressing *On/Off* at any time; even if other buttons are pressed simultaneously.

If there is a residual heat of a hotplate remaining, this will be indicated in the correspondent heat setting Heat Level Display as a red “H”.

# Operating Instruction

---

## Selecting A Cooking Zone

Select a single cooking zone by pressing the corresponding *Heater Selection Button*, and the *Decimal Point* of the chosen cooking zone turns on. For the selected cooking zone, you can set or adjust the heat level between 1-9 by touching the *Sliding Button* at the appropriate point. All of the other cooking zone displays will have a visible 'O' or 'H' (if recently used) but they will not have a decimal point.

If left idle for more than 10 seconds, the decimal point on the chosen cooking zone display will turn off (the cooking zone is no longer selected). Press the *Heater Selection Button* again to select the cooking zone again. Other cooking zones can be selected without waiting for the previous one to become inactive.

The Heat Level Display works on a thermostat system. This means that the cooking zone will switch on and off in order to remain at the chosen Heat Level.

NOTE the cooking zone will remain on for longer periods if a higher Heat Level is chosen, alternatively the cooking zone will be on less regularly on lower Heat Level Settings.

## Turning Off Individual Cooking Zones

A particular cooking zone can be turned off in 2 different ways:

A) Selecting the cooking zone & then simultaneously pressing the *Sliding Button* at either end at the same time, after which a beep signal sounds and "0" appears in the Heat Level Display.

B) Reduction of the heat setting to "0" by operating the *Sliding Button* to the left. When this happens, the associated *Decimal Point* of the cooking zone will also be turned off. If there is residual heat from this hotplate remaining, a red 'H' will be shown in the Heat Level Display area.

## The Boost Function

The *Boost* function is available at each cooking zone. It is used to speed up the initial heat up time (say boil a pot of water). Select a cooking zone and set the Heat level. While the decimal point on the display is lit, press the *Boost* button. The display will alternate between "P" and the heat setting.

Note: The *Boost* function is not always available (depending on what else is being used), and if the power requirements are exceeded, the display will flash with an alternative setting for 3 seconds. Do not leave the appliance unattended while this function is active.

To disable the *Boost* function, press the *Heater Selection Button* for the cooking zone again (so the *Decimal Point* is lit) and adjust the heat setting with the *Sliding Button*. The display will no longer alternate between "P" and the heat setting.

## The Smart Pause Function

This function reduces the power of all cooking zones for 30 minutes (at which point the appliance will turn off). Activate by pushing the *Smart Pause Button*. The displays will alternate between " " and their correct reading. Turn the function off by pressing the button a second time.

# Operating Instruction

---

## Locking The Keys

The child lock is used to set the appliance up so when it is first turned on, it is in a locked mode (which must be unlocked before a cooking function can take place). While locked, touch modifications (e.g. increase heat settings) and others will not be possible. It is only possible to switch the appliance off.

Turn the appliance on, but do not activate any functions. Press the *Sliding Button* at both ends at the same time, and then the right end of the *Sliding Button* again. The display shows an “L” on all cooking zone displays (or alternating “H” & “L”) and will remain locked even if the unit is turned off & on.

To unlock the unit, press the *Sliding Button* at both ends at the same time, and then the left end of the *Sliding Button* again. The “L” displays will switch back to the heat settings and will not be active when the unit is next turned on.

The *Key Lock button* can be used to stop access to any functions (except the *On/Off* function) while the cooktop is being used. Once the cooktop has been set up to cook, press the *Key Lock button* for 2 seconds until there is an audible alarm and the key lock symbol will be lit. Repeat the process to remove the key lock (the key lock symbol will no longer be lit). If the unit is turned off & on, the key lock will remain active.

## TOUCH CONTROL SAFETY FUNCTIONS

The following safety functions are available to avoid unintended operations of the cooktop control:

### Hotplate Safety Cut Off

To prevent the appliance from unwanted, random button operation, a sensor monitoring is included.

In the case of one or more buttons being pressed longer than 12 seconds, the sensor monitoring routine indicates acoustically that an “error” (pot or other object placed on the button, sensor failure, etc.) has occurred and switches off the appliance.

If residual heat is present, it will be displayed in all other Heat Level Displays with a red “H”.

### Over Temperature Switch Off

Because the controls are very close to the hotplates on the front of the cooktop, it is possible that a pot can be placed half on the control and not sensed by the sensor safety cut off (not covering a sensor). This can cause the cooktop to heat up to a very high temperature, which makes the glass and the buttons untouchable without burning a finger.

To prevent the cooktop control unit from damage caused by overheating, a temperature sensor is available on the touch control unit which will turn the appliance off when overheating occurs.

### Spill Function

The cooktop has a sensor that detects if liquids are spilled on the control panel. This shows up as a flashing “F” in each Heat level display (even when the unit is not operating). The easiest remedy is to clean/dry the control panel with a moistened cloth and leave for a minute to dry. If the display is not repeated it is safe to continue cooking.

# Operating Instruction

---

## Operating Time Limitation

The cooktop control has a limitation on the operating time. If the heat setting for a hotplate has not been changed for a certain time, then the hotplate will turn off automatically (a "0" is displayed for 10 seconds, then the residual heat sign "H" is displayed). The limit of the operating time depends on the selected heat setting.

Heat settings 1-2: 6 hours.

Heat settings 3-4: 5 hours.

Heat setting 5: 4 hours.

Heat settings 6-9: 1.5 hours.

After an automatic turn off of a hotplate (as described above) the hotplate is operable again and the maximum operating time for this heat setting is re-applied.

## Residual Heat Functions

After all cooking processes there is some heat stored in the vitroceramic glass called residual heat. The control can calculate roughly how hot the glass is in the worst case. If the calculated temperature is higher than + 60 ° C, then this will be indicated in the corresponding Heat Level Display after the hotplate control has turned off with a red "H". The residual heat display is shown as long as the calculated heater temperature is > + 60 ° C.

The display of the residual heat has the lowest priority and is overwritten by every other display value, during safety turn offs and the display of an error code.

When the supply voltage is re-applied to the cooktop after an interruption to the supply voltage, the residual heat display flashes if the corresponding hotplate had a residual heat of greater + 60 ° C before the power interruption occurred. The display will flash until the maximum residual heat time has expired or the hotplate has been selected and activated.

## Minute Minder (1-99 minutes)

The minute minder allows to set up a timer that does not affect the operation of the heating elements (the heating elements must be off when set). Press the *timer button* & the timer display will show the current set time (to start, 00) with a blinking decimal point. Use the *Sliding Button* to adjust the time. After 10 seconds of no changes, the time will be set, the decimal point will stop blinking and the timer will begin to count down. At the end of the time, the alarm will sound for 30 seconds unless stopped by pressing a button. The time can be adjusted at any time by pressing the timer button to activate the timer & adjusting with the *Sliding Button*.

## Cooking Zone Timer (1-99 minutes)

The Cooking Zone Timer can be set to control individual heating elements. Activate a heating element & set the heat level. While still active, press the *timer button* and adjust the time as for the Minute minder. Multiple heating elements can be set up with different times. There are 4 LEDs around the timer display which represent the timers for the 4 heating elements, and which heating element is going to run out next (the timer display shows this).

When a timer runs out, the alarm will sound for 30 seconds, the timer display will flash 00, the LED representing the heating element will flash and the heating element will turn off. After 30 seconds (or a button is pressed), the timer will switch to the next shortest timer set (if all heating elements have turned off, the cooktop will turn off). Timers can be adjusted in the same way at any time.

## Cleaning and Maintenance



**NOTE:** Cleaning and maintenance operations must only be carried out when the cooktop is cool (all residual heat indicators are off).

The appliance should be disconnected from the power outlet or turned off at your isolation switch before commencing any cleaning process.

Do not use plastic, plastic coated or aluminium cooking equipment on this appliance.

### CLEANING THE COOKTOP

All cookware used on this appliance should be rated for induction cooking by the manufacturer. Cookware with rough bases should not be used as they can scratch the glass ceramic surface. The base of the good cookware should be as thick and flat as possible. Before use, make sure that cookware bases are clean and dry.

Always place the cookware on the cooking zone before it is switched on. If possible, always place the lids on the cookware. The base of any cookware used must not be smaller or larger than the cooking zones; they should be the proper size as indicated below, so as not to waste energy. If incorrectly placed, the U symbol will be displayed.

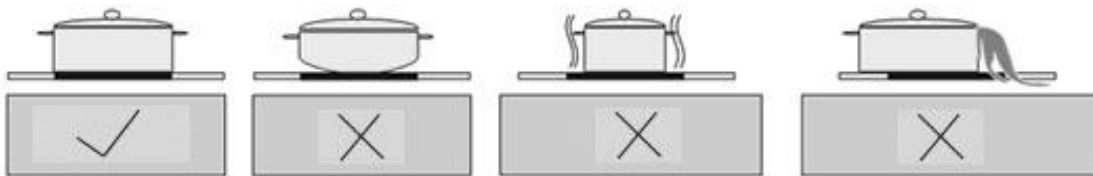

Before cleaning the cooktop, first isolate the cooktop from the power. Once done, ensure that there is no residual heat stored in the appliance. Vitroceramic glass is very resistant to high temperature and overheating. If there is residual heat stored in the appliance, the related residual heat indicator lamp will be on. In order to avoid burns, let the appliance cool down.

Remove all spilt food and fat with a clean damp, warm, slightly soapy, dishcloth. Rinse cloth and wipe cooktop again until clean, then wipe the cooktop dry with a clean tea towel or dry soft cloth.

If aluminium foil or plastic items are accidentally melted on the vitroceramic surface, they should be immediately removed from the hot cooking area with a scraper specifically for vitroceramic glass. This will avoid any possible damage to the surface. This also applies to sugar or food containing sugar that may be spilled on the cooktop. Enamelled steel, aluminium & copper will leave a residue on the surface that should be removed immediately or permanent damage may occur.

In the event of other food melted on the cooktop surface, remove the dirt when the appliance has cooled down. Use cleaner for glass ceramic or stainless steel when cleaning the surface.

Do not use abrasive sponges to clean the vitroceramic surface. These materials may damage the surface.

Do not use chemical detergents, sprays or spot removers on the vitroceramic surface. These materials may cause fire or the vitroceramic colour to fade. Clean with a damp, warm, slightly soapy, dishcloth.

**WARNING:** Using cookware that is too large can cause discolouration or damage to the cooktop surface around the heat zones, which is **NOT** covered under warranty.



# Australian & New Zealand Product Warranty Statements of Standard Warranty Conditions

## Australian Customers

Our goods come with guarantees that cannot be excluded under the Australian Consumer Law. You are entitled to a replacement or refund for a major failure and for compensation for any other reasonably foreseeable loss or damage. You are also entitled to have the goods repaired or replaced if the goods fail to be of acceptable quality and the failure does not amount to a major failure.

## New Zealand Customers

Nothing herein contained shall be construed in any way as excluding or limiting your rights under the Consumer Guarantee Act 1993.

## Our Warranty

This product is also covered by the manufacturer's warranty set out in this document (Our Warranty).

Our Warranty is for a period of twenty four (24) months from the date of purchase and for refrigeration appliances will have an additional thirty six (36) months after the first twenty four (24) months on the Sealed System (PARTS only) Compressor & condenser etc. The labour cost to replace these parts is the responsibility of the customer. This is in addition to (and does not exclude, restrict or modify) any rights or remedies to which you may already be entitled under the Australian Consumer Law or the New Zealand Consumer Guarantee Act 1993 relating to this product. Our Warranty (which is subject to the conditions below) covers rectification free of charge of any fault arising from defective materials or components, or faulty workmanship. The product will be repaired or replaced at the option of Omega, and all costs of installation, removal, cartage, freight travelling expenses and insurance are to be paid by the customer.

Our Warranty is subject to the following conditions:

1. That the purchaser contact Omega prior to any product repair.
2. That the purchaser carefully follows all instructions provided with the product and complies with all relevant electrical & plumbing regulations in their State when installing the product.
3. That the purchaser carefully follows the instructions provided in the owner's handbook relating to the proper use and care of the product and does not use the product for any purpose other than the DOMESTIC use for which it has been designed. If the appliance is used in commercial applications or for rental purposes, Our Warranty is limited to a warranty of Twelve (12) months covering all parts with Three (3) months on any labour cost of service or repair.

## Service Area

The provision of service under Our Warranty is limited by the boundary / territory area of the nearest service centre. Travelling cost incurred for service outside this area is not covered by Our Warranty

and service will incur commercial cost to be paid by the customer regulated by the number of kilometres travelled beyond the service area. These costs will be disclosed to you for acceptance by you prior to your claim being processed.

Microwave ovens must be returned to your nearest Authorised Service Centre for repair as they are a carry in serviceable appliance.

## What is Covered by our Warranty

During the warranty period, Omega or its authorised Service Centre will, at no extra charge, if your appliance is readily accessible without the need of special equipment and subject to the terms and conditions of this warranty, repair or replace any parts which it considers defective.

## What is not Covered by our Warranty

1. Products installed damaged or incomplete or not in compliance with the relevant electrical & plumbing regulations in their State.
2. Normal wear and tear e.g. cleaning, light globes, filters etc.
3. Failure resulting from power surges and electrical storms.
4. Insect or vermin infestation.
5. Unauthorised repairs or use of non genuine Omega parts.
6. Any failure caused by the product not being used in accordance with the instruction and the installation manual provided with the product.
7. Misuse or abuse, including failure to properly maintain or service.
8. The clearing of blockages in pumps and hoses.
9. Damage which occurs during delivery or installation.
10. Claims to product surface coating due to liquid or solid spill-overs, accidental damage or damage caused from cleaning products not recommended by Omega.

## How to Claim Our Warranty

While registering your warranty is not a requirement, for peace of mind you can register your warranty at [omegaplacements.com.au](http://omegaplacements.com.au).

To make a claim under Warranty you will need to contact Omega in Australia or New Zealand by using the contact details below.

If you are contacting Omega regarding any warranty claims and spare parts inquiries, please make sure you have the following information on hand:

1. Product Name/Model Number
2. Serial Number/s
3. Purchase Date (as per invoice or proof of purchase)
4. Purchased From
5. Warranty Registration Number (if registered)

## Contact Us Australia

Omega is a division of Shriro Australia Pty Ltd  
Phone: 1300 739 033  
Email: [customercare@omegaplacements.com.au](mailto:customercare@omegaplacements.com.au)

## Contact Us New Zealand

Omega is a division of Monaco Corporation (member of Shriro)  
Phone: 09 415 6000  
Email: [customercare@monacocorp.co.nz](mailto:customercare@monacocorp.co.nz)

For peace of mind note down your serial number here: \_\_\_\_\_



