

28L Built-In Microwave

OM28BF

omega

Designed to Enhance
EST. 1981

@omegaappliances_au
omegaappliances.com.au

Contents

Welcome	03
Safety Information	04
Installation Instructions	06
Your Microwave	12
Operating Instructions	14
Cleaning & Maintenance	16
Troubleshooting	17
Product Specifications	18
Purchase Details	19
Warranty Information	20

Welcome

Residentia Group

—

Head Office

165 Barkly Avenue
Burnley Victoria
Australia 3121

—

ACN

600 546 656

—

Online

residentia.group
omegaappliances.com.au
@omegaappliances_au

—

Postage

PO BOX 5177, Burnley
VIC Australia 3121

—

Telephone

1300 11 4357

—

Email

support@residentia.group

Congratulations on purchasing your 28L Built-In Microwave. Omega appliances are proudly owned and distributed within Australia by Residentia Group Pty Ltd.

Please refer to the warranty chapter at the rear of this manual for information regarding your product's parts and labour warranty, or visit us online at:

→ residentiagroup.com.au

Here at Residentia Group, we are customer obsessed and our Support Team are there to ensure you get the most out of your appliance. Should you want to learn more about your unit, and importantly, taking care of the appliance, our Support Team are here to help. You can use our online Support Centre at any time by visiting:

→ support.residentiagroup.com.au

Or you can contact us by dialling: 1300 11 HELP (4357)

It is important that you read through the following user manual thoroughly, in order to familiarise yourself with the installation and operation requirements of your appliance, and to ensure optimum performance.

Again, thank you for choosing an Omega appliance. We look forward to being of service to you.

Kind Regards,
The Residentia Team

Customer Care

—

At Residentia Group, we strongly encourage the use of authentic spare parts to guarantee the best results. When contacting our spare parts team through 1300 11 HELP, or by emailing parts@residentiagroup.com.au, please ensure that you have the model and serial numbers on hand, which are found on your appliances' rating plate.

Safety Information

Important Safety Instructions

- To reduce the risk of fire, electric shock, injury to persons or exposure to excessive microwave oven energy when using your appliance, follow basic precautions, including the following steps below.
- Do not attempt to operate this oven with the door open since this can result in harmful exposure to microwave energy. It is important not to break or tamper with the safety interlocks.
- Do not place any object between the oven front face and the door or allow soil or cleaner residue to accumulate on sealing surfaces.
- **WARNING:** If the door or door seals are damaged, the oven must not be operated until it has been repaired by a competent person. If the apparatus is not maintained in a good state of cleanliness, its surface could be degraded and affect the lifespan of the apparatus and lead to a dangerous situation.
- This appliance is not intended for use by persons (including children) with reduced physical, sensory or mental capabilities, or lack of experience and knowledge, unless they have been given supervision or instruction concerning use of the appliance by a person responsible for their safety.
- Children should be supervised to ensure that they do not play with the appliance.
- If the supply cord is damaged, it must be replaced by the manufacturer, its service agent or similarly qualified persons in order to avoid a hazard. (For appliance with type Y attachment).
- **WARNING:** Ensure that the appliance is switched off before replacing the lamp to avoid the possibility of electric shock.
- **WARNING:** It is hazardous for anyone other than a qualified person to carry out any services or repairs that involve the removal of a cover which gives protection against exposure to microwave energy.
- **WARNING:** Liquids and other foods must not be heated in sealed containers since they are often liable to explode.
- When heating food in plastic or paper containers, keep an eye on the oven cavity due to the possibility of ignition.
- Only use utensils that are considered suitable or safe for use in microwave ovens, (see page 05 for chart).
- If smoke is emitted, switch off or unplug the appliance and keep the door closed in order to stifle any flames.
- Microwave heating of beverages can result in delayed eruptive boiling, therefore care must be taken when handling the container.
- The contents of feeding bottles and baby food jars shall be stirred or shaken and the temperature checked before consumption, in order to avoid burns.
- Eggs in their shell and whole hard-boiled eggs should not be heated in microwave ovens since they may explode, even after microwave heating has ended.
- The oven should be cleaned regularly and any food deposits removed.
- Failure to maintain the oven in a clean condition could lead to deterioration of the surface that could adversely affect the life of the appliance and possibly result in a hazardous situation.
- Only use the temperature probe recommended for this oven. (For ovens provided with a facility to use a temperature-sensing probe.)
- The microwave oven must be operated with the decorative door open. (For ovens with a decorative cabinet door.)
- This appliance is intended to be used in household and similar applications such as: staff kitchen areas in shops, offices and other working environments; by clients in hotels, motels and other residential type environments; farm houses; and bed and breakfast type environments.
- The microwave oven is intended for heating food and beverages. Drying of food or clothing and heating of warming pads, slippers, sponges, damp cloth and similar may lead to risk of injury, ignition or fire.
- Metallic containers for food and beverages are not allowed during microwave cooking.
- This microwave should under no circumstances be cleaned with a steam cleaner.
- The appliance must not be installed behind a decorative door in order to avoid overheating. (This is not applicable for appliances with decorative door.)

Safety Information (Continued)

Microwave Safe Materials

Utensils	Information
Browning Dish	Follow manufacturer's instructions. The bottom of browning dish must be at least 3/16 inch (5mm) above the turntable. Incorrect usage may cause the turntable to break.
Dinnerware	Microwave-safe only. Follow manufacturer's instructions. Never use cracked or chipped dishes.
Glass Jars	Always remove lid. Use only to heat food until just warm. Most glass jars are not heat resistant and may break.
Glassware	Heat-resistant oven glassware only. Make sure there is no metallic trim. Never use cracked or chipped dishes.
Oven Bags	Follow manufacturer's instructions. Never close the bag/s with a metal bread tie. Make slits to allow steam to escape.
Paper Plate/Cups	Use for short-term cooking/warming only. Do not leave oven unattended while cooking.
Paper Towels	Use to cover food for reheating and absorbing fat. Always use for short-term cooking only.
Parchment Paper	Use as a cover to prevent splattering or a wrap for steaming.
Plastic	Microwave-safe only. Follow the manufacturer's instructions. Should be labeled "Microwave Safe". Some plastic containers soften, as the food inside gets hot. "Boiling bags" and tightly closed plastic bags should be slit, pierced or vented as directed by package.
Plastic Wrap	Microwave-safe only. Use to cover food during cooking to retain moisture. Do not allow plastic wrap to touch food, as in some circumstances it can melt.
Thermometers	Microwave-safe only (meat and candy thermometers).
Wax Paper	Use as a cover to prevent splattering and retain moisture.

Unsafe Materials (Do not use)

Utensils	Information
Aluminium Trays	May cause arcing. Transfer food into microwave-safe dish.
Metal Containers	May cause arcing. Transfer food into microwave-safe dish.
Metal Utensils	Metal shields the food from microwave energy. Metal trim may cause arcing.
Metal Bread Ties	May cause arcing and could cause a fire in the oven.
Paper Bags	May cause a fire in the oven.
Plastic Foam	Plastic foam may melt or contaminate the liquid inside when exposed to high temperature.
Wood	Wood will dry out when used in the microwave oven and may split or crack.

Installation Instructions

Installation Safety Instructions

- **DANGER:** Electric Shock Hazard. Touching some of the internal components can cause serious personal injury or death. Do not disassemble this appliance.
- **WARNING:** Electric Shock Hazard. Improper grounding can result in electric shock. Do not plug into an outlet until the appliance is properly installed and grounded. This appliance must be grounded. In the event of an electrical short circuit, grounding reduces the risk of electric shock by providing an escape for the electric current. This appliance is equipped with a cord equipped with a grounding wire and grounding plug. The plug must be securely plugged into an outlet that is properly installed and grounded.
- Consult a qualified electrician or service technician if the grounding instructions are not completely understood or if doubt exists as to whether the appliance is properly grounded. If it is necessary to use an extension cord, use only a 3-wire
- A short power-supply cord is provided to reduce the risks resulting from becoming entangled in or tripping over a longer cord.
- If a long cord set or extension cord is used, the marked electrical rating of the cord set or extension cord should be at least as great as the electrical rating of the appliance. The extension cord must be a grounding-type 3-wire cord.
- The long cord should be arranged so that it will not drape over the counter or tabletop where it can be pulled on by children or tripped over unintentionally.

Installation & Connection

- 1 This appliance is only intended for domestic use.
- 2 This oven is intended for built-in use only. It is not intended for counter-top use, or for freestanding use inside a cupboard.
- 3 Please observe the special installation instructions.
- 4 The appliance can be installed in a 60cm wide wall-mounted cupboard.
- 5 The appliance is fitted with a plug and must only be connected to a properly installed earthed socket.
- 6 The mains voltage must correspond to the voltage specified on the rating plate.
- 7 The socket must be installed and connecting cable must only be replaced by a qualified electrician. If the plug is no longer accessible following installation, an all-pole disconnecting device must be present on the installation side with a contact gap of at least 3mm minimum.
- 8 Adapters, multi-way strips and extension leads must not be used. Overloading can result in a risk of fire.



Please note, the accessible surface may be hot during operation.

Installation Instructions (Continued)

Electrical Connection

The oven is fitted with a plug and must only be connected to a properly installed earthed socket. The socket must only be installed and the connecting cable must only be replaced by a qualified electrician, and in accordance with the appropriate regulations. If the plug is no longer accessible following installation, an all-pole isolating switch must be present on the installation side, with a contact gap of at least 3mm.

The fitted cabinet must not have a back wall behind the appliance. A gap must be maintained between the wall and the base of the unit above. Specific gap size could be referenced by the diagrams.

Minimum installation height: 85cm.

Do not cover ventilation slots and suction holes.

NOTE: Do not trap or bend the power cable.

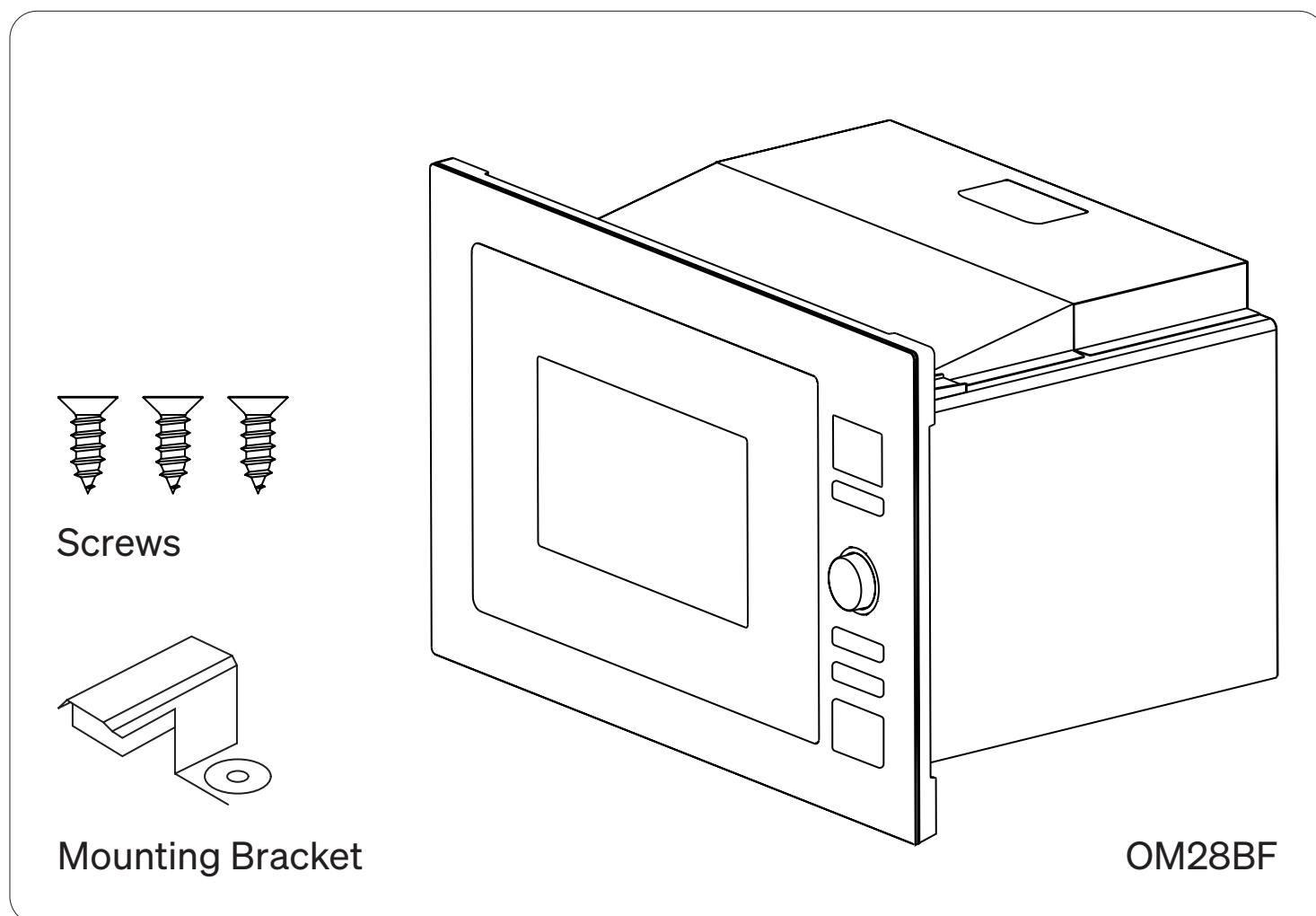

Installation Instructions (Continued)

Please Follow the Cabinetry Specifications Below:

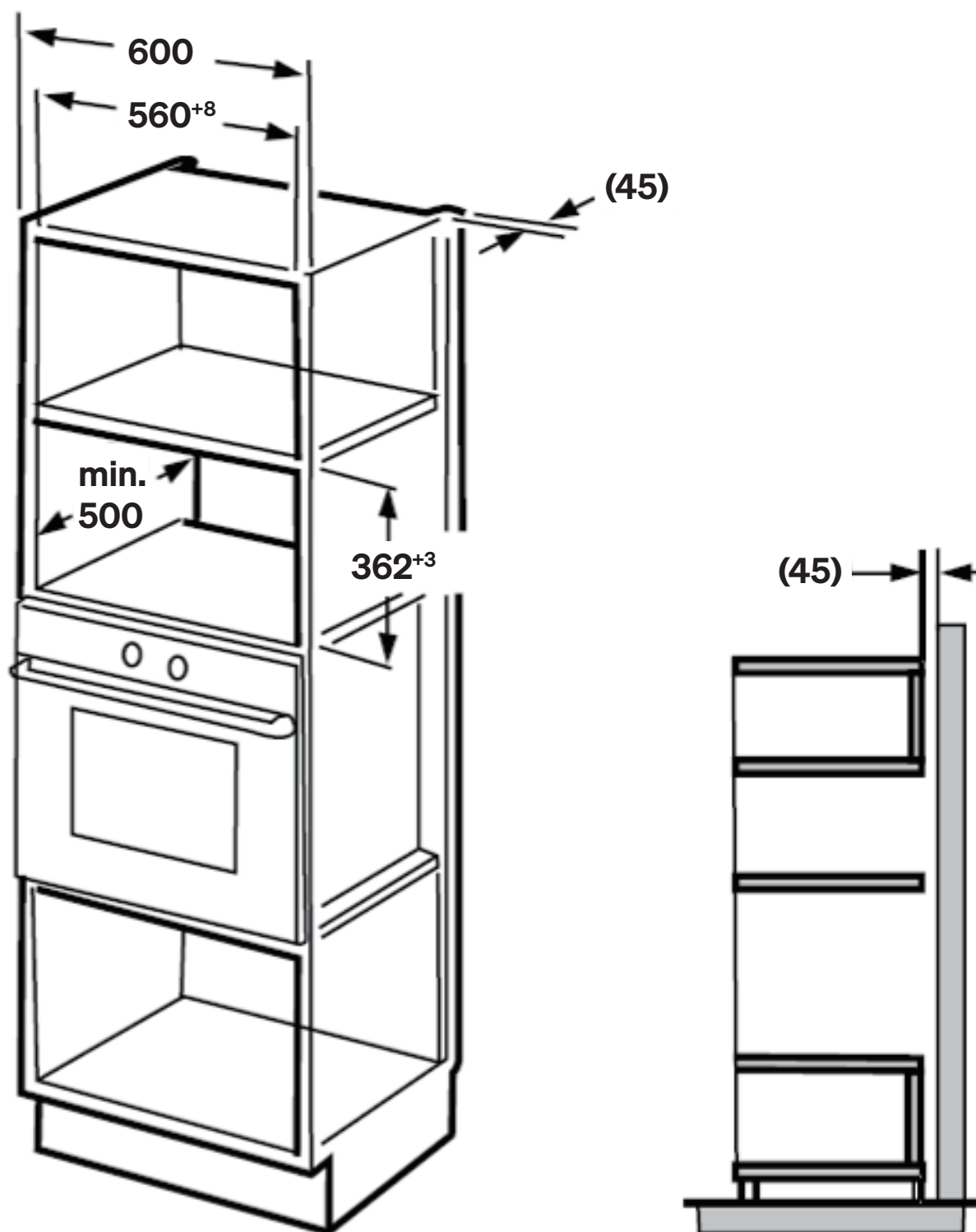

Installation Instructions (Continued)

Preparing the Cabinet

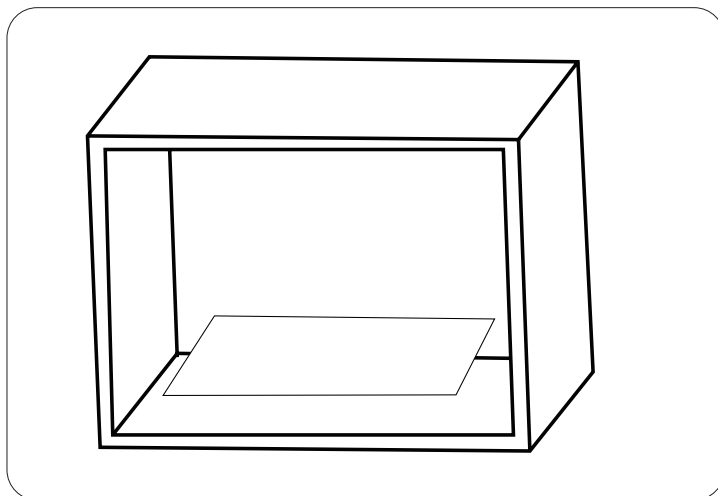

- 1 Read the instructions contained in the supplied Cabinetry Installation Template, and place the template on the bottom plane of cabinet.

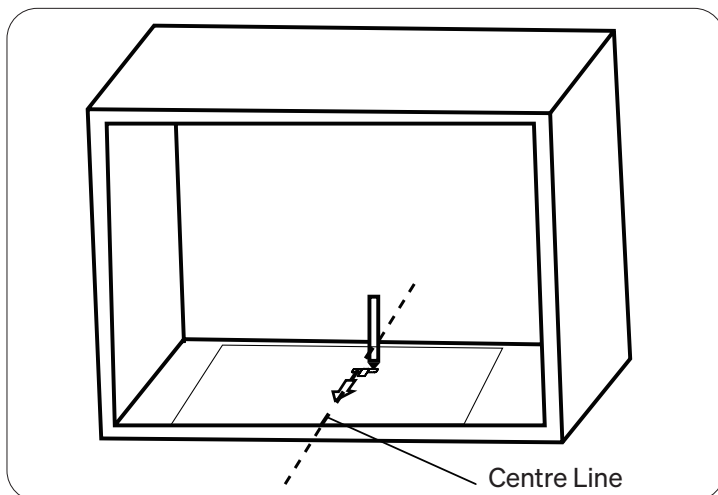

- 2 Make the marks on the bottom plane of cabinet according to marks **A** of the template.

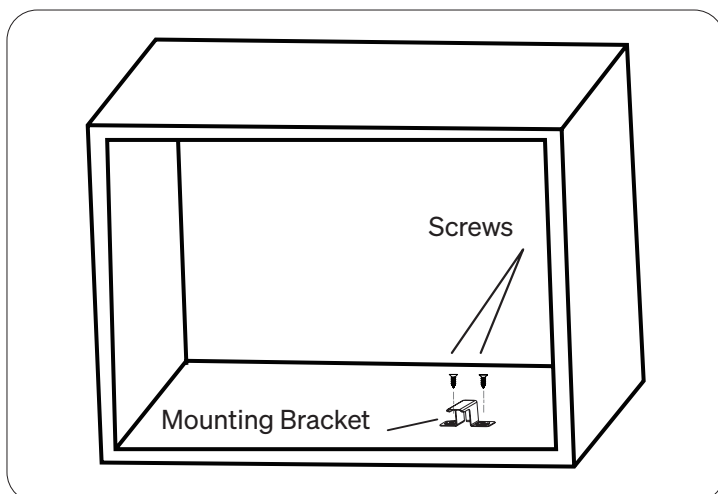

- 3 Remove the Cabinetry Installation Template and fix the mounting plate with the supplied screws.

Installation Instructions (Continued)

Securing Your Microwave

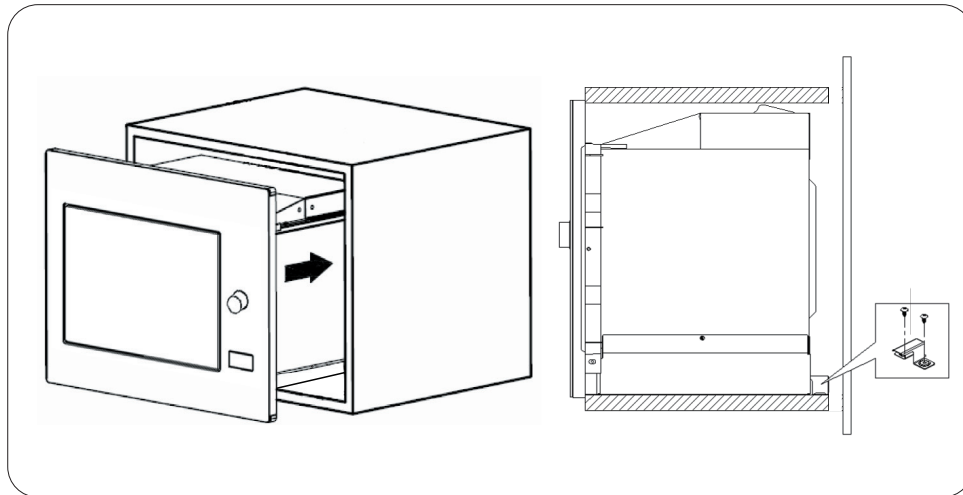

- 4 Install the oven to the cabinet. Make sure the back of the oven is locked by mounting plate. Ensure you do not trap or kink the power cord.

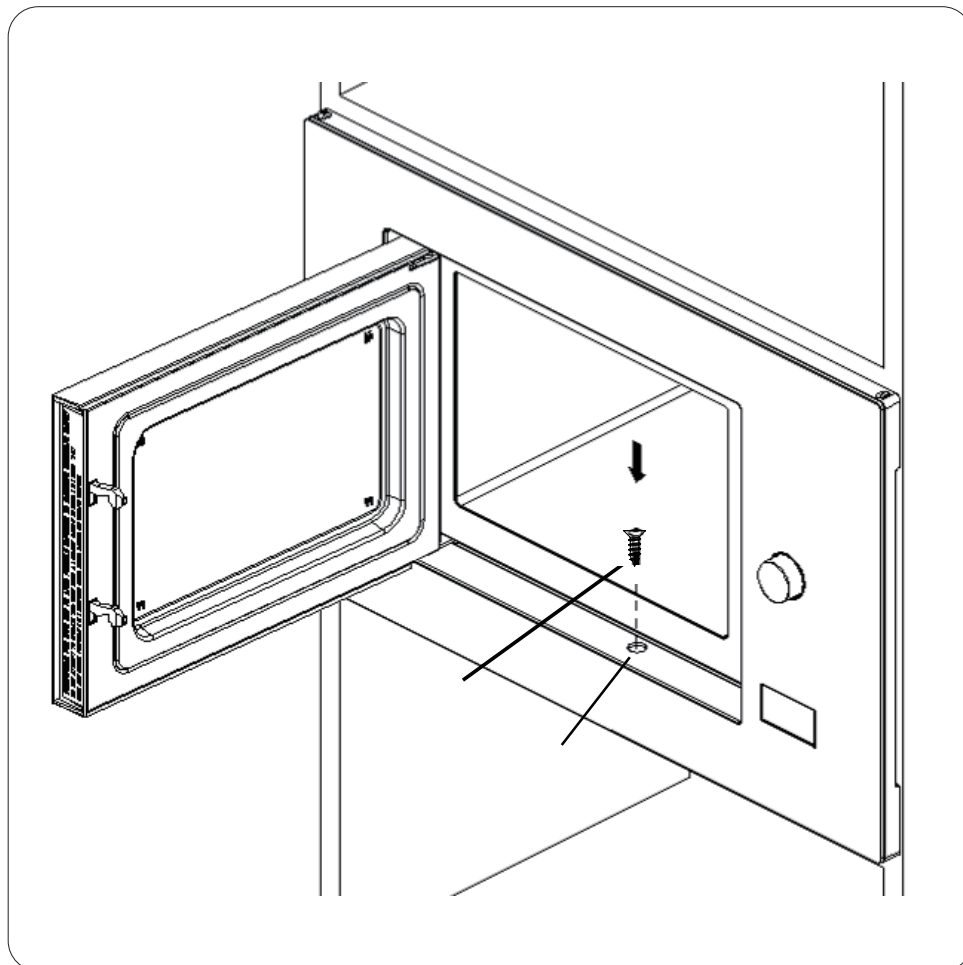

- 5 Open the door, fix the oven to the cabinet with Screw, at the installation hole.

Installation Instructions (Continued)

Turntable Installation

Make sure all packaging and shipping tape has been removed from the turntable shaft. Before using the appliance to prepare food for the first time, you will need to put the turntable in place correctly. You must clean the cooking compartment and accessories.

How to put the turntable in place:

- 1 Place the turntable ring assembly **(3)** into the recess in the cooking compartment.
- 2 Place the glass tray **(1)** on the turntable ring assembly **(3)**. Fit the raised, curved lines in the center of the glass tray bottom between the three spokes of the shaft. Make sure that the glass tray **(1)** engages in the turntable shaft **(2)** in the centre of the cooking compartment floor. The rollers on the **(3)** should fit inside the turntable bottom ridge.

Turntable Tips

- 1 Never use the appliance without the turntable installed. Ensure that it is properly engaged. The turntable can turn clockwise or anti-clockwise.
- 2 Never place the glass tray upside down. The glass tray should never be restricted.
- 3 Both glass tray and turntable ring assembly must always be used during cooking.
- 4 All food and containers of food are always placed on the glass tray for cooking.
- 5 Never restrict the movement of the turntable.
- 6 If glass tray or turntable ring assembly cracks or breaks, promptly contact Omega for a replacement.

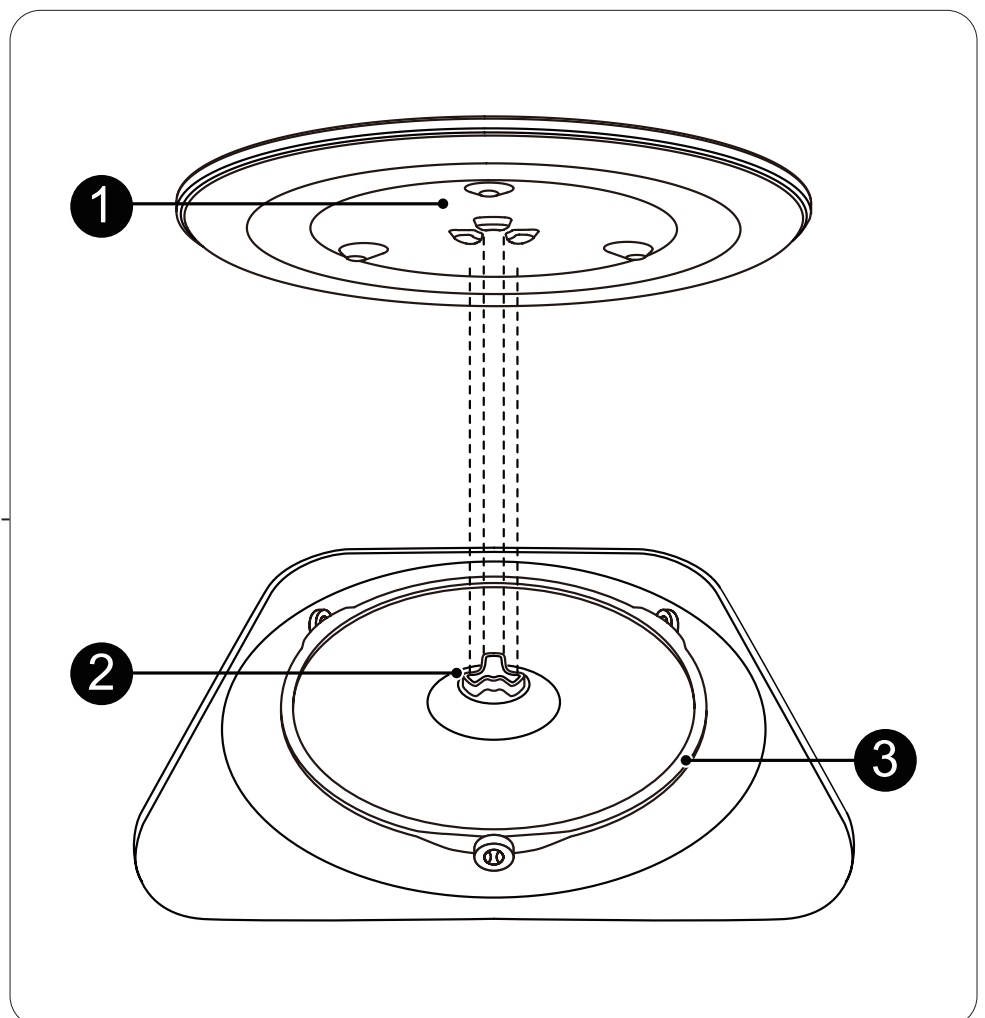
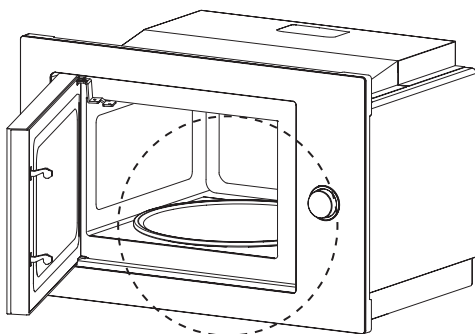

Your Microwave

Oven Parts and Accessories

Your oven comes with the following accessories:

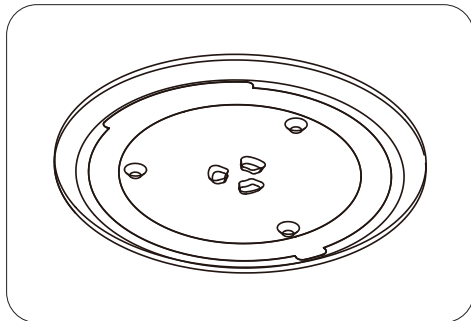

Glass Tray

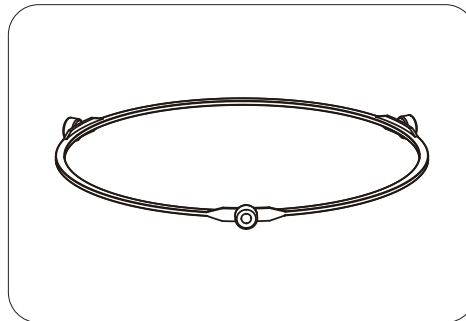

Turntable Ring

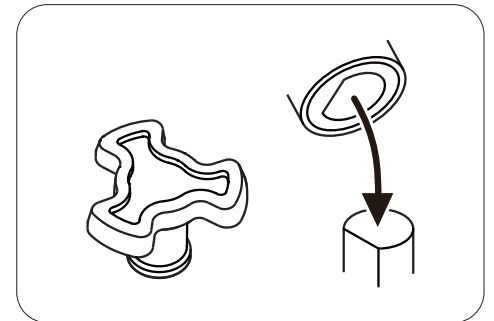

Turntable Shaft

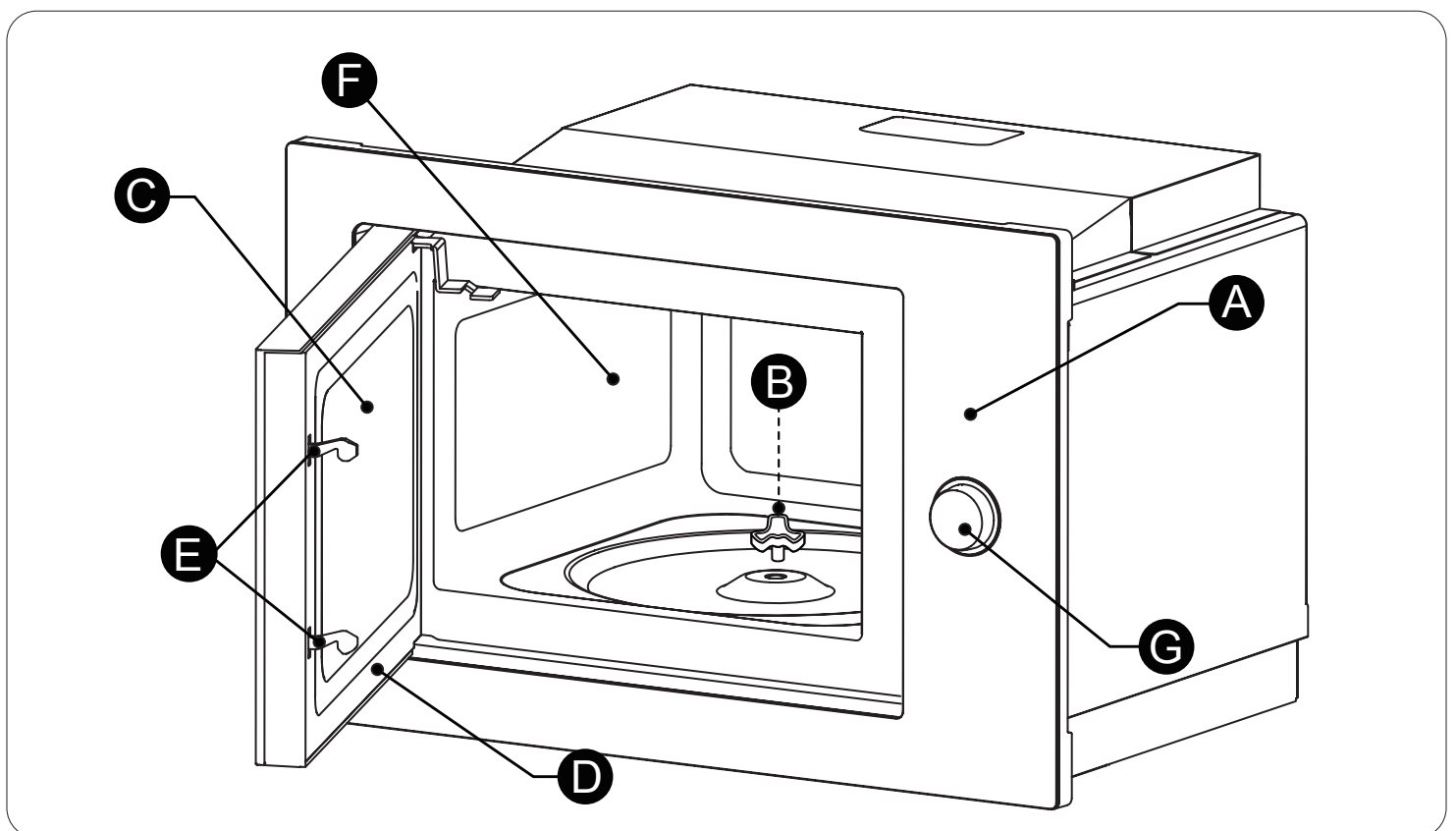

A Control Panel

C Observation Window

E Safety Interlock System

B Turntable Shaft

D Door Assembly

F Oven Cavity

G Control Dial

Your Microwave (Continued)

Control Panel

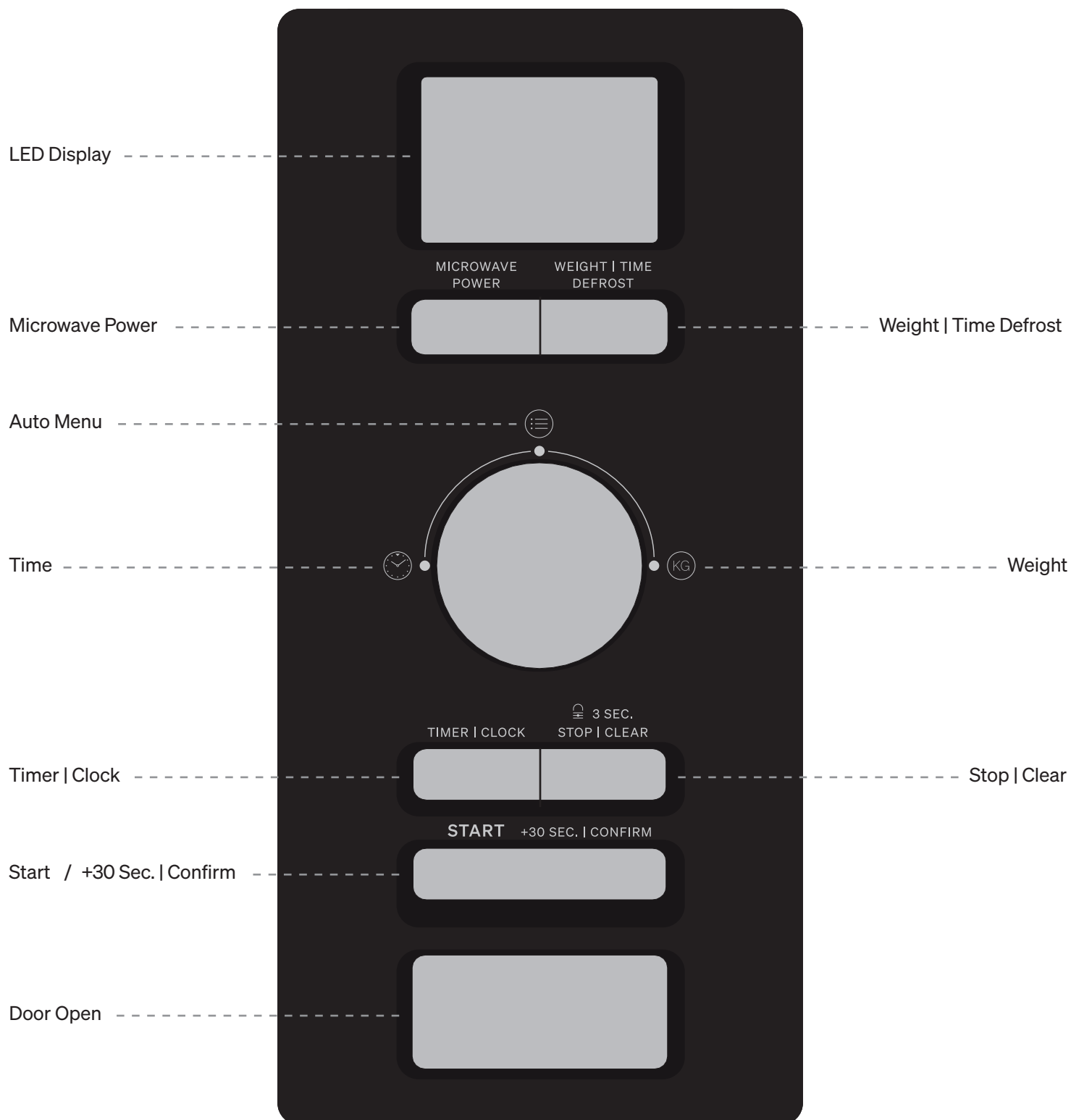

Operating Instructions

Installation Safety Instructions

- 1 When the microwave oven is first turned on, the LED will display **0:00**, and the buzzer tone will ring once.
- 2 Press the **TIMER | CLOCK** button twice to select clock function, the hour figures will flash.
- 3 Turn the dial clockwise to adjust the hour figures, the input time should be within 0–23.
- 4 Pressing the **TIMER | CLOCK** button confirms the hour. The minute figures will then flash, indicating they are ready to be selected.
- 5 Turn the dial clockwise to adjust the minute figures, the input time should be within 0–59.
- 6 Press the **TIMER | CLOCK** button to confirm your clock setting. The **:** will flash, and the time will light.

NOTE: The clock function will not work if it is not set when the microwave is first powered on.

Microwave Cooking

- 1 Pressing the **MICROWAVE POWER** button, the LED will display **P100**. Pressing **MICROWAVE POWER** repeatedly or turning the dial allows you to choose the power setting you prefer, from **P100, P80, P50, P30** etc.
- 2 Once you have found the desired power setting, press the **START** button to confirm, and turn the dial to set the cooking time from **0:05** to **95:00**. Pressing the **START** button will then begin the cooking process.

Setting the Clock

- 1 Pressing the **TIMER | CLOCK** button once, the LED will display **00:00**.
- 2 Turn the dial to enter the desired cooking time, (Note that the maximum cooking time is 95 minutes).
- 3 Press the **START** button to begin your chosen setting.

NOTE: The kitchen timer itself is not a cooking program, and is intended for keeping track of time only.

Child Safety Lock

- **LOCK:** Press and hold the **STOP | CLEAR** button for 3 seconds. A tone will sound and the child safety will be set.
- **UNLOCK:** Press and hold the **STOP | CLEAR** button for 3 seconds. A tone will sound and the lock will be turned off.

Quick Start

- 1 In waiting state, simply pressing the **START** button will start cooking with 100% power for 30 seconds.
- 2 Alternatively, you can turn the dial anti-clockwise to set the power to 100% and the cooking time to 90 minutes, then press the **START** button to begin cooking.

NOTE: Each press of the **START** button increases the cooking time by 30 second increments.

Defrost by Weight

- 1 Press the **WEIGHT | TIME DEFROST** button once, and the oven will display **dEF1**.
- 2 Turn the dial to select the food's weight, choosing from 100g to 1000g.
- 3 Press the **START** button to start defrosting.

Defrost by Time

- 1 Press the **WEIGHT | TIME DEFROST** button twice, and the oven will display **dEF2**.
- 2 Turn the dial to select the defrost time. The maximum time is 95 minutes.
- 3 Press the **START** button to start defrosting. Note that the defrost power is **P30** by default, and cannot be changed.

Multi-Stage Cooking

- 1 At most 2 separate stages can be set for the cooking process. When using multi-stage cooking, if one of the selected stages is defrosting, then defrosting will always be prioritised as the first stage.
- 2 The kitchen timer and auto-menu can not be used as part of the multi stage process.
- 3 Press the **START** button to increase the cooking time by 30 second increments.

Inquiry Function

- 1 At any point during the cooking process, pressing **MICROWAVE POWER** will display the current power setting for 3 seconds.
- 2 Similarly, at any point during the cooking process pressing **TIMER | CLOCK** will temporarily display the current time for 3 seconds.

Operating Instructions (Continued)

Auto-Menu

- 1 Turn the dial clockwise to choose the auto-menu, in which case codes **A-1** through to **A-8** will display. These codes refer to different programs designed for cooking specific dishes.
- 2 Once you have selected the desired program code, press the **START** button to confirm.
- 3 Turn the dial to select between the available default food weight settings.
- 4 Press the **START** button to begin cooking.

Auto-Menu Table

Menu	Weight	Display
A-1 (Pizza)	200g	200
	400g	400
A-2 (Meat)	250g	250
	350g	350
	450g	450
A-3 (Vegetable)	200g	200
	300g	300
	400g	400
A-4 (Pasta)	50g +450g cold water	50
	100g +800g cold water	100
A-5 (Potato)	200g	200
	400g	400
	600g	600
A-6 (Fish)	250g	250
	350g	350
	450g	450
A-7 (Beverage)	1 Cup ^(120ml)	1
	2 Cups ^(240ml)	2
	3 Cups ^(360ml)	3
A-8 (Popcorn)	50g	50
	85g	85
	100g	100

Cleaning & Maintenance

General Cleaning Instructions

- ALWAYS unplug the appliance from the power supply when cleaning.
- Regularly clean the cavity of the oven after use with a slightly damp cloth.
- For particularly messy uses, clean the accessories in the usual way but with lightly soapy water.
- The door frame and seal and neighbouring parts must be cleaned carefully with a damp cloth when they are dirty.
- Do not use harsh abrasive cleaners or sharp metal scrapers to clean the oven door glass as they can scratch the surface, which may result in shattering of the glass.
- Cleaning Tip: For easier cleaning of the cavity walls that cooked food can stain: Place half a lemon in a bowl, add 300ml (½ pint) water and heat on 100% microwave power for 10 minutes. Wipe the oven clean using a soft, dry cloth.

Troubleshooting

Problem	Possible Cause	Solution
Microwave Oven Interfering with the TV's Reception	Your radio and TV's reception may experience some interference when the microwave is operating. It is similar to the interference of small electrical appliances such as mixers, vacuum cleaners, and electric fans. It is normal.	-
Dim Oven Light	When low power microwave cooking, the oven light may become dim. This dim light is normal, and not to be a cause for concern.	-
Steam Accumulating On Door, Hot Air Coming Out of Vents	In cooking, steam may come out of food. Most will get out from vents. But some may accumulate on cool place like oven door. It is normal.	-
Microwave oven started accidentally, with no food in.	It is forbidden to run the unit without any food inside. It is very dangerous.	Cancel the program immediately.
Oven cannot be started.	Power cord is not plugged in tightly.	Unplug. Then plug again after waiting for 10 seconds.
	Fuse blowing or circuit breaker works.	Replace fuse or reset circuit breaker (repaired by professional personnel of Omega).
	Trouble with outlet.	Test the outlet with other electrical appliances to see if it functions correctly and safely.
Oven does not heat.	Door is not properly closed.	Close the door properly



According to Waste of Electrical and Electronic Equipment (WEEE) directive, WEEE should be separately collected and treated. If at any time in future you need to dispose of this product please do NOT dispose of this product with household waste. Please send this product to WEEE collecting points where available.



Product Specifications

Model Number	OM28BF
Microwave Cavity	28L
Product Dimensions (W × D × H)	595 × 410 × 388mm
Packaging Dimensions (W × D × H)	653 × 500 × 466mm
Net Weight	16.9kg
Gross Weight	19.5kg
Rated Power	1450W
Power Supply	220-240V, ~50Hz

Purchase Details

For future reference, please record the following information which can be found on the rating plate and the date of purchase which can be found on your sales invoice.

STORE DETAILS

Store Name		
Address		
Telephone		Purchase Date

PRODUCT DETAILS

Model No.		
Serial No.		

Attach Your Receipt Here

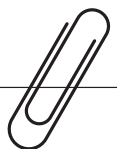

Warranty Information

WARRANTY TERMS AND CONDITIONS BUILT-IN MICROWAVES

This document sets out the terms and conditions of the product warranties for Residentia Group Appliances. It is an important document. Please keep it with your proof of purchase documents in a safe place for future reference should you require service for your Appliance.

1. IN THIS WARRANTY

- (a) 'acceptable quality' as referred to in clause 10 of this warranty has the same meaning referred to in the ACL;
 - (b) 'ACL' means Trade Practices Amendment (Australian Consumer Law) Act (No.2) 2010;
 - (c) 'Appliance' means any Residentia Group product purchased by you accompanied by this document;
 - (d) 'ASR' means Residentia Group authorised service representative;
 - (e) 'Residentia Group' means Residentia Group Pty Ltd of 165 Barkly Ave, Burnley VIC 3121, ACN 600 546 656 in respect of Appliances purchased in Australia;
 - (f) 'major failure' as referred to in clause 10 of this warranty has the same meaning referred to in the ACL and includes a situation when an Appliance cannot be repaired or it is uneconomic for Residentia Group, at its discretion, to repair an Appliance during the Warranty Period;
 - (g) 'Warranty Period' means:
 - (i) where the Appliance is used for personal, domestic or household use (i.e. normal single family use) as set out in the instruction manual, the Appliance is warranted against manufacturing defects for 24 months, following the date of original purchase of the Appliance;
 - (h) 'you' means the purchaser of the Appliance not having purchased the Appliance for re-sale, and 'your' has a corresponding meaning.
2. This warranty only applies to Appliances purchased and used in Australia and is in addition to (and does not exclude, restrict, or modify in any way) any non-excludable statutory warranties in Australia.
 3. During the Warranty Period Residentia Group or its ASR will, at no extra charge if your Appliance is readily accessible for service, without special equipment and subject to these terms and conditions, repair or replace any parts which it considers to be defective. Residentia Group or its ASR may use remanufactured parts to repair your Appliance. You agree that any replaced Appliances or parts become the property of Residentia Group. This warranty does not apply to light globes, batteries, seals, filters or similar perishable parts.
 4. Parts and Appliances not supplied by Residentia Group are not covered by this warranty.

Warranty Information (Continued)

5. You will bear the cost of transportation, travel and delivery of the Appliance to and from Residentia Group or its ASR. If you reside outside of the service area, you will bear the cost of:
 - (a) travel of an authorised representative;
 - (b) transportation and delivery of the Appliance to and from Residentia Group or its ASR, in all instances, unless the Appliance is transported by Residentia Group or its ASR, the Appliance is transported at the owner's cost and risk while in transit to and from Residentia Group or its ASR.
6. Proof of purchase is required before you can make a claim under this warranty.
7. You may not make a claim under this warranty unless the defect claimed is due to faulty or defective parts or workmanship. Residentia Group is not liable in the following situations (which are not exhaustive):
 - (a) the Appliance is damaged by:
 - (i) accident
 - (ii) misuse or abuse, including failure to properly maintain or service
 - (iii) normal wear and tear
 - (iv) power surges, electrical storm damage or incorrect power supply
 - (v) incomplete or improper installation
 - (vi) incorrect, improper or inappropriate operation
 - (vii) insect or vermin infestation
 - (viii) failure to comply with any additional instructions supplied with the Appliance;
 - (b) the Appliance is modified without authority from Residentia Group in writing;
 - (c) the Appliance's serial number or warranty seal has been removed or defaced;
 - (d) the Appliance was serviced or repaired by anyone other than Residentia Group, an authorised repairer or ASR.
8. This warranty, the contract to which it relates and the relationship between you and Residentia Group are governed by the law applicable where the Appliance was purchased.
9. To the extent permitted by law, Residentia Group excludes all warranties and liabilities (other than as contained in this document) including liability for any loss or damage whether direct or indirect arising from your purchase, use or non use of the Appliance.
10. For Appliances and services provided by Residentia Group in Australia, the Appliances come with a guarantee by Residentia Group that cannot be excluded under the Australian Consumer Law. You are entitled to a replacement or refund for a major failure and for compensation for any other reasonably foreseeable loss or damage. You are also entitled to have the Appliance repaired or replaced if the Appliance fails to be of acceptable quality and the failure does not amount to a major failure. The benefits to you given by this warranty are in addition to your other rights and remedies under a law in relation to the Appliances or services to which the warranty relates.
11. At all times during the Warranty Period, Residentia Group shall, at its discretion, determine whether repair, replacement or refund will apply if an Appliance has a valid warranty claim applicable to it.
12. Missing parts are not covered by warranty. Residentia Group reserves the right to assess each request for missing parts in a case by case basis. Any parts that are not reported missing in the first week after purchase will not provide free of charge.
13. To enquire about claiming under this warranty, please follow these steps:
 - (a) carefully check the operating instructions, user manual and the terms of this warranty;
 - (b) have the model and serial number of the Appliance available;
 - (c) have the proof of purchase (e.g. an invoice) available;
 - (d) telephone the numbers shown below.
14. You accept that if you make a warranty claim, Residentia Group and its ASR may exchange information in relation to you, in order to enable Residentia Group to meet its obligations under this warranty.

IMPORTANT

Before calling for service, please ensure that the steps in point 13. have been followed.

CONTACT SERVICE

→ Please call 1300 11 HELP (4357)

The Australian Consumer Law requires the inclusion of the following statement with this warranty:

Our goods come with guarantees that cannot be excluded under the Australian Consumer Law. You are entitled to a replacement or refund for a major failure and for compensation for any other reasonably foreseeable loss or damage. You are also entitled to have the goods repaired or replaced if the goods fail to be of acceptable quality and the failure does not amount to a major failure.



EST. 1981

Designed to Enhance

omega

Omega is proudly owned in Australia
by Residentia Group Pty. Ltd.

@residentia.group
www.residentia.group