



**omega**

Instruction Manual

OMEGA 90CM BUILT-IN ELECTRIC OVEN

---

OBO960XTGG

OBO960X

OBO960X1

OBO960XB

# Thank you for purchasing an Omega appliance

Tailored for the modern aesthetic and lifestyle of busy people, your new Omega Appliance will make a welcome addition to the family.

Omega caters to style-savvy customers who look for balance between stunning form and clever function. This means a combination of sleek, chic, sophisticated design yet effortless functionality. And we source from the best. The best craftsmanship. The best innovation. From the best international design-houses.

All brought together under an appliance that stands for design-led balance.

Please take the time to read through the following instruction manual to familiarise yourself with the installation, operation requirements and maintenance to ensure optimum performance.

## Further Information

For important information about your Omega Appliance such as warranty registration, manuals, features, and specifications please visit [omegaappliances.com.au](http://omegaappliances.com.au) (if you are in Australia) and [omegaappliances.co.nz](http://omegaappliances.co.nz) (if you are in New Zealand) or contact our Customer Care team on the below email or phone numbers.

## Registering Your Warranty

For peace of mind you can register your warranty at [omegaappliances.com.au](http://omegaappliances.com.au). Further information on the Warranty can be found at the end of this manual.

## Contact Us

Our customer service team is here to help you with any question or concern. Both teams are on call Monday to Friday 9.00am to 5.00pm and of course you can always send an email at your convenience.

### Australia Contact Details

Monday to Friday 9.00am – 5.00pm  
Email: [support@residentiagroup.com.au](mailto:support@residentiagroup.com.au)  
Phone: 1300 11 4357

### New Zealand Contact Details

Monday to Friday 9.00am – 5.00pm  
Email: [customercare@monacocorp.co.nz](mailto:customercare@monacocorp.co.nz)  
Phone: 09 415 6000

To stay up to date and find simple and easy recipes, follow us on our socials:

[facebook.com/omegaappliances](https://facebook.com/omegaappliances)  
[instagram.com/omegaappliances\\_au](https://instagram.com/omegaappliances_au)

**READ THE INSTRUCTION BOOKLET BEFORE INSTALLING AND USING THE APPLIANCE.**

**It is important that you retain these instructions, proof of purchase as well as other important documents about this product for future reference.**

**The manufacturer will not be responsible for any damage to property or to persons caused by incorrect installation or improper use of the appliance.**

*Due to continual product development, Omega reserves the right to alter specifications and appearances without notice.*

**Contents**

---

Important Safety Warnings .....4-5  
Appliance Details ..... 6  
Electrical Connections ..... 7  
Installation Instructions .....8-9  
Operating Instructions .....10-16  
Cleaning ..... 19  
Troubleshooting ..... 18  
Warranty .....21

**Disposal Information**

---

- Most of the packaging materials are recyclable. Please dispose of these materials through your local recycling depot or by placing them into appropriate collection containers.
- If you wish to discard this product, please contact your local authorities and ask for the correct method of disposal.

## Important Safety Warnings

---

**IMPORTANT:** Read the assembly instruction section and safety precautions of this booklet carefully before removing the contents of this carton.

1. This appliance is not intended for use by persons (including children) with reduced physical, sensory or mental capabilities, or lack of experience or knowledge, unless they have been given supervision or instructions concerning the use of the appliance by a person responsible for their safety. Children should be supervised to ensure that they do not play with the appliance.
2. In certain circumstances electrical appliances may be a safety hazard.
3. Do not place heavy objects in or on these appliances, use for storage or let children play/swing from the door. These appliances are designed for cooking food only.
4. This appliance is designed for domestic household use only and for the cooking of domestic food products. Use as a commercial appliance will void the warranty. It should not be used in a marine environment or outdoors.
5. This appliance is supplied with cables for single phase connection (min Ø1.5mm). It is a high-powered appliance and must be installed by an authorised person.
6. If the electrical supply cord is damaged, either when being installed or after installation, it must be replaced by the manufacturer, its service centre or similarly a qualified person in order to prevent a hazard.
7. The electrical connection must be accessible after installation. The appliance must be electrically isolated before any maintenance can be performed.
8. Electrical connection must be made as per local wiring rules and regulations. Do not disconnect the appliance with wet hands or bare feet, and do not disconnect the power cord with extreme force. If the electricity supply is restricted, means of an all-pole disconnection must be accessible and incorporated in the fixed wiring in accordance with the wiring rules.
9. Always grasp the oven door in the centre of the handle as the areas around the door edges may be hot due to the escape of hot air.
10. Ensure that the kitchen is well ventilated or mechanical ventilation is in use while cooking with this appliance.
11. Do not store or use flammable materials or aerosols near the oven. Items made from aluminium, plastic or plastic film should also be kept away from the appliance, as they may fuse to the surface.
12. Never line the oven bottom with aluminium foil, as the consequent accumulation of heat could compromise the cooking and even damage the enamel.
13. **WARNING** – Accessible parts will become hot when in use. Young children should be kept away. During use the oven becomes hot. Care should be taken to avoid touching heating elements inside the oven. Do not touch any components during this time, as they may be hot and can cause burns. Use heat resistant cooking gloves where possible when moving food and cooking utensils in and out of the oven.
14. Cleaning may only be commenced on the appliance once it has cooled down (best slightly warm). The appliance should be disconnected from the power outlet or turned off at your isolation switch before commencing any cleaning process. Do not use a steam jet or any other high pressure cleaning equipment to clean the appliance. Follow oven cleaner directions if these are being used. **WARNING:** Ensure the appliance is switched off before replacing the lamp to avoid the possibility of electric shock.

15. Wash all accessories in hot soapy water or in a dishwasher, wipe dry with a paper or cloth towel. If you use your oven for an extended period of time, condensation may form. Dry it using a soft dry cloth.
16. When the appliance is not being used, the knobs must be kept in the 'OFF' position.
17. Where this appliance is installed in a caravan, it shall NOT be used as a space heater.
18. Do not modify this appliance.
19. Do not use harsh abrasive cleaners or sharp metal scrapers to clean the glass oven door glass as it can scratch the surface, which may result in the glass shattering. Clean the glass door using warm damp cloth and dry it with a soft cloth.
20. All cabinetry and materials used in the installation must be able to withstand a minimum temperature of 100°C above the ambient temperature of the room it is located in, whilst in use. Certain types of vinyl or laminate kitchen furniture are particularly prone to heat damage or discolouration at temperatures outside the guidelines given above. Any damage caused by the appliance being installed without adhering to the temperature limits set out above will be the liability of the owner.
21. This appliance must be correctly installed by a suitably qualified person, strictly in accordance with the manufacturer's instructions. Please see the specific section of this booklet that refers to installation.
22. The appliance must be installed and put in operation by an authorised technician under the conditions provided by the manufacturer in this manual. The manufacturer cannot be held responsible for any damage that might occur due to faulty installation.
23. The values indicated on the printed documents found on the product are values obtained in laboratory environment according to relevant standards. These values may vary according to the usage and environment conditions of product.
24. This oven must not be installed behind a decorative door in order to avoid overheating.

## Appliance Details

---

### Electrical Details

Models	OBO960X OBO960X1 OBO960XB OBO960XTGG
Voltage Rating	220-240V ~50Hz
Power Rating	3600W
Supply Connection	Hardwired to power supply

### Dimensions

LENGTH (mm)	DEPTH (mm)	HEIGHT (mm)	CAVITY (L)
900	570	595	129

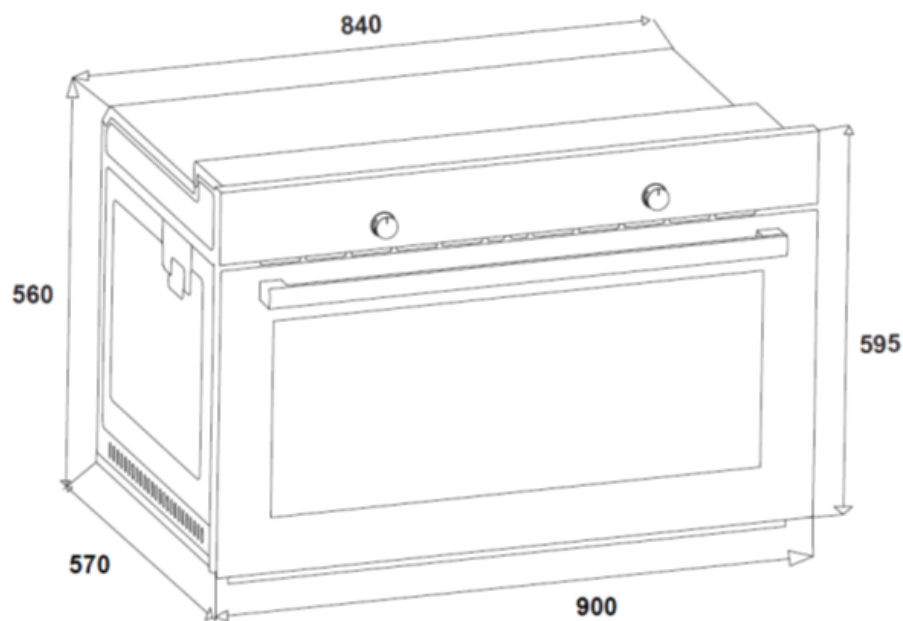

## Electrical Connections

---



### LOCAL AUTHORITY REQUIREMENTS

Installation is only permitted by a licensed electrician and carried out according to instructions provided by the manufacturer. Incorrect installation might cause harm and damage which the manufacturer accepts no responsibility.

### ELECTRICAL INSTALLATION FOR THE LICENSED ELECTRICIAN

This oven must be connected to a 220-240V 50Hz power supply.

Before carrying out the connection to the power supply, the voltage rating of the appliance (stamped on the appliance identification plate) must be checked for correspondence to the available mains supply voltage, and the mains electric wiring should be suitable for the oven's power rating (also indicated on the appliance identification plate);

The switched outlet must be connected to a suitable earth wiring, in conformity to current safety regulations.

A circuit breaker with a contact opening of at least 3mm **MUST** be installed inside the supply circuit. It should not be located above the appliance and no more than 1.25m away from it. The power supply cord must not touch any hot surfaces and must be placed so that its temperature does not exceed 75°C at any point along its length. After having installed the appliance, the switched outlet must always be in an accessible position.

**NOTE:** For connections to the mains power supply, never use adapters, reductions or multiple power points as these may overheat and catch fire.

The mains terminal block is located on the back of the oven and the terminals are accessible by opening the terminal block cover.

**Note:** The terminal cover should not be opened when the mains power is still connected to the appliance and never by an unauthorized person.

The electrical safety of this appliance can only be guaranteed if the oven is correctly and efficiently earthed. The manufacturer declines all responsibility for damage resulting from an installation which has not been earthed correctly. The use of adapters, multiple sockets and/or extensions, is not allowed.

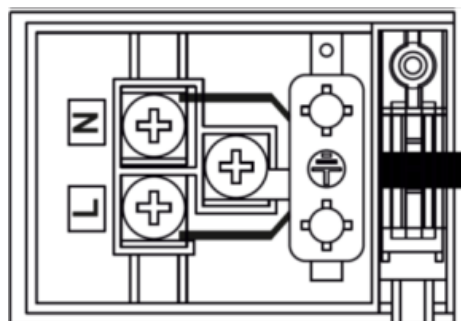

## Installation Instructions



The adjacent furniture must be able to withstand a minimum temperature rise of 100°C above the ambient temperature of the room it is located in during periods of use. The power supply to the appliance must be cut off before any adjustments or maintenance work is done on it.

### PREPARATION FOR INSTALLATION AND USE

Manufactured with best quality parts and materials, this modern, functional and practical oven will meet your needs in all respects. Make sure to read the manual to obtain successful results so as not to experience any problems in the future. The information given below contains rules that are necessary for correct positioning and service operations. They should be read without fail, especially by the technician who will position the appliance.

### CHOOSING A PLACE FOR THE APPLIANCE

There are several factors to consider when choosing a place for your oven. Make sure to take into account our recommendations below in order to prevent any problems and dangerous situations which might arise.

When choosing a place for the oven, attention should be paid to ensure there are no flammable or combustible materials in the close vicinity, such as curtains, oil, cloth etc. which quickly catch fire.

Furniture surrounding the oven or cooktop must be made of materials resistant to temperatures of at least 100°C.

Required changes to wall cabinets and exhaust fans above a built-in cooktop as well as minimum heights from the oven board are shown below. Accordingly, a rangehood should be at a minimum height of 65 cm from the cooktop. If there is no rangehood the height should not be less than 70 cm. Refer to the rangehood instructions for specific details before installation.

If there is a drawer below the oven, a protective board must be placed between the oven and drawer.

A cooling fan draws air in from the appliance sides to cool the outer surfaces and removes excess steam through the front of the oven (above the door). This fan will continue to operate for some time after the cooking sequence has finished. Ventilation space must be allowed beside and behind the oven; failure to do so can cause damage to both the appliance and surrounding cupboards.

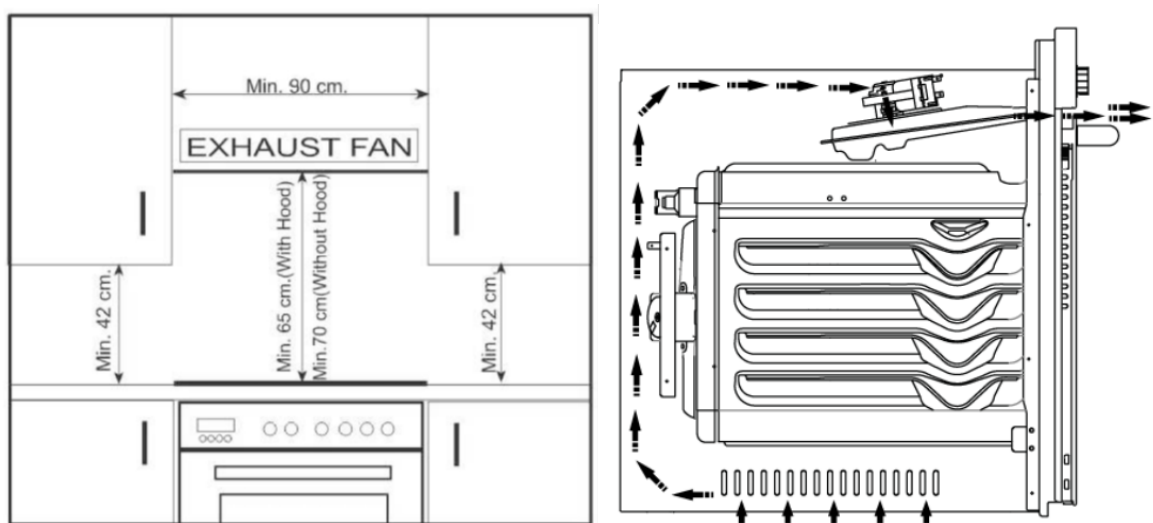

**omega**



## Installation Instructions

### INSTALLATION OF BUILT-IN OVEN

Insert the oven into cabinet partly by pushing it forward. Open the oven door and insert 2 screws into the holes on the oven frame. While the product frame touches the wooden surface of the cabinet, tighten the screws.

If the oven is installed below a built-in hob, the distance between the worktop and the top panel of the oven must be a minimum of 50mm, and the distance between the worktop and the top of the oven control panel must be a minimum of 25mm. The front of the oven will remain in front of the cabinet.

The dimensions and material of the cabinet in which the oven will be installed must be correct and resistant to increases in temperature. In a correct installation, contact with electrical or insulated parts must be prevented. Insulating parts need to be fitted in a way to ensure that they cannot be removed by using any kind of tool.

Installing the appliance in the close vicinity of a refrigerator or a deep-freezer is not recommended as the performance of the above-mentioned appliances will be negatively affected due to emanating heat. After removing your oven from its packaging, be sure that the oven is not damaged. If you suspect any damage to the appliance, do not use it; immediately contact an authorised Service Centre.

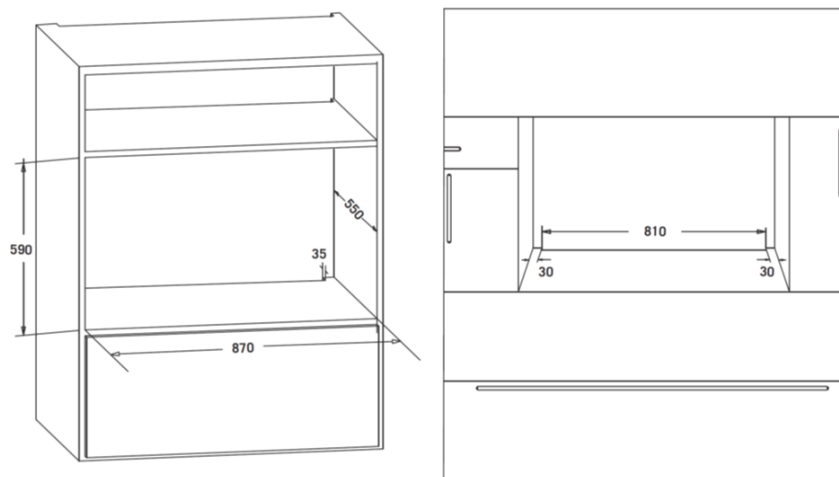

INSTALLATION IN AN ELEVATED CABINET

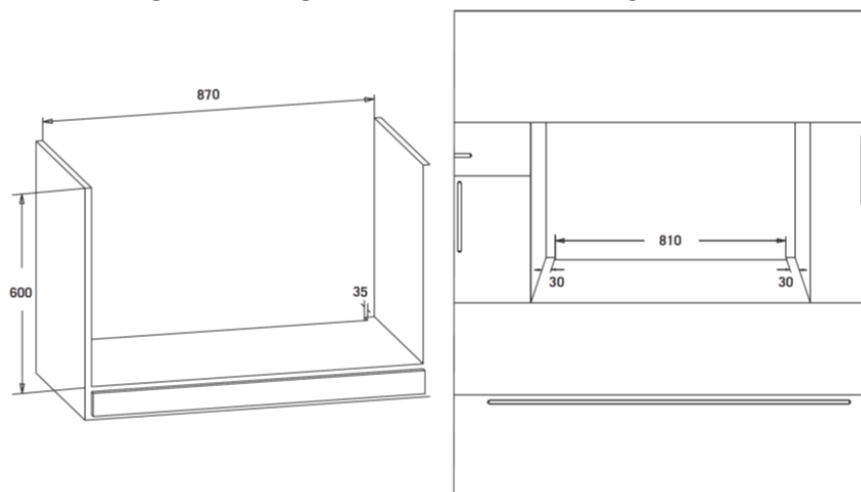

INSTALLATION UNDER A BENCHTOP

## Operating Instructions

---

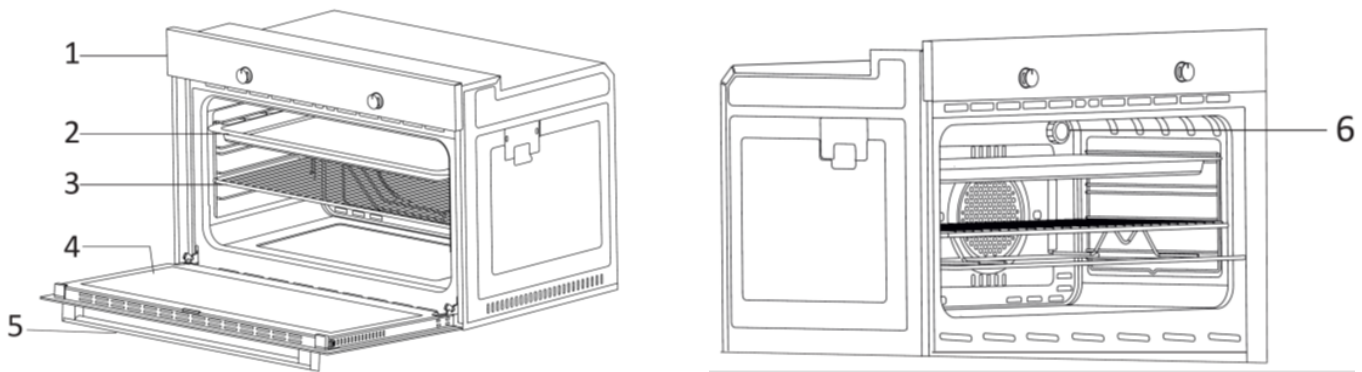

- |    |                |    |             |
|----|----------------|----|-------------|
| 1. | Control Panel. | 4. | Door.       |
| 2. | Tray.          | 5. | Handle.     |
| 3. | Wire Rack.     | 6. | Light (x2). |

When you first run your oven, a certain smell will be emanated arising from the insulation materials and the heater elements. For this reason, before using your oven, run it empty at maximum temperature for 45 minutes. At the same time, you need to properly ventilate the environment in which the oven is installed.

In order to cook in your oven, the oven function and temperature setting controls need to be adjusted and the oven timer, if available, needs to be programmed. Otherwise, the oven will not operate.

Unplug your appliance when it is not in use.

Protect your appliance from atmospheric effects. Do not leave it under the effects of the sun, rain, snow, dust etc.

### ENERGY SAVING

Choose cookware of an appropriate size. Using a lid will reduce cooking times. Minimize the amount of liquid or fat to reduce cooking times. Oven door should not be opened often during cooking period.

## Operating Instructions

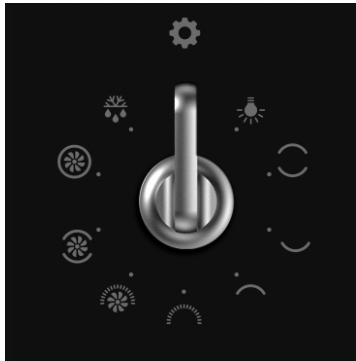

FUNCTION CONTROL KNOB

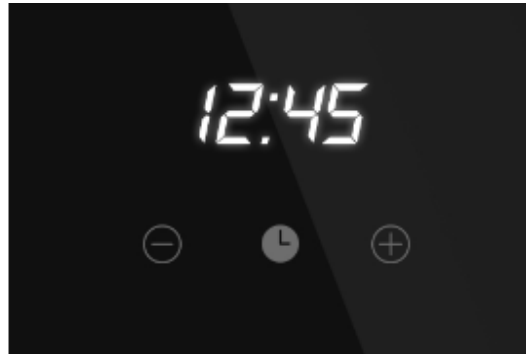

TOUCH BUTTON TIMER

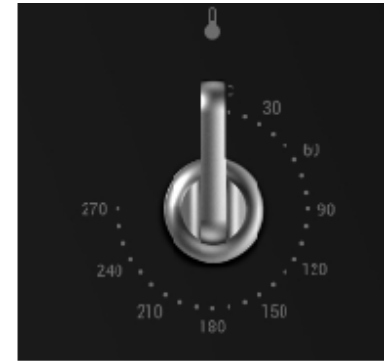

THERMOSTAT CONTROL KNOB

### OVEN FUNCTION CONTROL

The oven function control is used to select the different functions. Each is explained in detail further in the manual. To select a function, turn the control knob to the desired oven function and then set the temperature with the thermostat control.

### OVEN THERMOSTAT CONTROL

The oven thermostat control is used to select the desired temperature for cooking. When the temperature inside your oven reaches the value set, the thermostat will cut the circuit and the thermostat light will go off. When the temperature falls below the set value, the thermostat will again be turned on alongside the thermostat light. It is normal for this to occur during the cooking process, particularly when the door has been opened.

### OVEN TIMER CONTROL

The 3-button timer is situated in the centre of the control panel.



#### OVEN STATUS ICON.

If on, oven is ready for cooking, or is cooking. If off, the oven is not cooking.



#### MINUTE MINDER ICON.

If on, the Minute Minder is running. If flashing, the minute minder can be adjusted using the minus & plus buttons. If off, the Minute Minder is not active.



#### CHILD LOCK ICON.

If on, the Child Lock is active. If off, the Child Lock is not active.



#### AUTOMATIC COOKING ICON.

If on, a timer function is running. If flashing, a timer function has completed or power has been reset. If off, no timer function is running.

## Operating Instructions

---

### TIME OF DAY ADJUSTMENT

When first turned on (or power has reset), the automatic cooking status icon will flash, indicating the time of day must be set for the oven to run correctly. Turn off oven functions. Press the plus and minus buttons simultaneously for 3 seconds until the digits flash. Adjust the time of day using the plus and minus buttons. The time is set 6 seconds after the last button is pressed (digits stop flashing).

### SETTING THE MINUTE MINDER

The minute minder is a timer that does not affect the cooking functions. Maximum length is 10 hours (in minute increments). Press the central timer button once to enter the minute minder mode (the minute minder icon flashes). While the icon is flashing, adjust the minute minder time using the plus and minus buttons. The time is set 6 seconds after the last button is pressed (icon stops flashing), or by pressing the central button once more. When time has elapsed, the buzzer will sound (for 5 minutes) and the minute minder icon flashes. Disable this by pressing any button.

### SETTING A COOKING DURATION TIMER FUNCTION

This timer function allows cooking to start immediately and finish after a pre-set time (up to 23 hours, 59 minutes). First place food in oven and set the oven function and cooking temperature. Press the central timer button twice. The automatic cooking icon will flash and the display will alternate between “dur” and the duration for cooking. Adjust the duration time with the plus and minus buttons. The duration is set 6 seconds after the last button is pressed (icon stops flashing) and the display will show the current time. When the duration has elapsed, the oven will turn off, the buzzer will sound (for 5 minutes) and the automatic cooking icon flashes. Turn the oven function and thermostat controls off and disable the buzzer by pressing any button.

### SETTING A FULLY AUTOMATIC TIMER FUNCTION

This timer function differs from the previous one with the cooking start time delayed. Set up the oven as above and set the duration for cooking. While the display is still flashing, press the central timer button one more time. The display will now alternate between “End” and the duration time. Use the plus and minus buttons to adjust the end time. The function is set 6 seconds after the last button is pressed (icon stops flashing) and the display will show the current time. The oven and oven status icon will turn off (as it is a delayed start) but the automatic cooking icon will continue to flash. When the time to start arrives, the oven and oven status icon will turn on, and the automatic cooking icon will stay on. Once the set duration has elapsed, the oven will turn off, the buzzer will sound (for 5 minutes) and the automatic cooking icon flashes. Turn the oven function and thermostat controls off and disable the buzzer by pressing any button.

### CHILD LOCK

The child lock is intended to stop any unauthorised adjustment of the timer functions, and comes on 30 seconds after a timer function is set. To deactivate it (to adjust a timer function), press and hold the central timer button for 3 seconds (the child lock icon will turn off and the buttons can be used).

## **SETTING THE BUZZER TONE**









There are 3 different buzzer tones. To adjust, first press the minus button for 3 seconds. Scroll through the tones by pressing the plus or minus buttons. The last tone heard will be the one set 6 seconds after the last button is pressed.

## **SETTING THE DISPLAY BRIGHTNESS**

There are 8 brightness settings. To adjust, press the plus button for 3 seconds. Scroll through the different settings by pressing the plus or minus buttons. The last brightness setting viewed will be set 6 seconds after the last button is pressed.

## Operating Instructions

### OVEN FUNCTION CONTROL CHART

	<b>LIGHT ONLY</b> THE OVEN LIGHT WILL TURN ON.
	<b>CONVENTIONAL</b> THE LOWER & UPPER HEATING ELEMENTS WILL SWITCH ON, ALONG WITH THE OVEN LIGHTS AND THE OVEN'S THERMOSTAT.
	<b>STEAM CLEAN</b> THE LOWER HEATING ELEMENT WILL SWITCH ON, ALONG WITH THE OVEN LIGHTS AND THE OVEN'S THERMOSTAT.
	<b>UPPER ELEMENT</b> UPPER HEATING ELEMENT WILL SWITCH ON, ALONG WITH THE OVEN LIGHT AND THE OVEN'S THERMOSTAT.
	<b>MAXI-GRILL</b> BOTH UPPER HEATING ELEMENTS WILL SWITCH ON, ALONG WITH THE OVEN LIGHT AND THE OVEN'S THERMOSTAT.
	<b>MAXI-GRILL WITH FAN</b> GRILL ELEMENT, UPPER HEATING ELEMENT AND FAN WILL SWITCH ON, ALONG WITH THE OVEN LIGHT AND THE OVEN'S THERMOSTAT.
	<b>FAN ASSIST</b> THE LOWER AND UPPER HEATING ELEMENTS, AND FAN WILL SWITCH ON, ALONG WITH THE OVEN LIGHT AND THE OVEN'S THERMOSTAT.
	<b>FAN FORCED</b> THE REAR HEATING ELEMENT AND FAN WILL SWITCH ON, ALONG WITH THE OVEN LIGHT AND THE OVEN'S THERMOSTAT.
	<b>DEFROST</b> THE FAN WILL SWITCH ON ALONG WITH THE OVEN LIGHTS TO PERFORM THE DEFROST FUNCTION.

**Note:** Oven shelves are numbered from 4 at the top down to 1 at the bottom.

During heated oven functions a cooling fan in the top of the oven will operate in order to cool down the oven door and kitchen cabinet as well as reducing condensation in the oven. There will then be a slight release of warm air from the top of the closed oven door. This is not a leak in heat from the oven cavity.

# Operating Instructions

---

## Oven Function Controls

### Defrost Function



You can start the defrost operation by putting the frozen food into oven and bringing the function control knob to the indicated mark. This function will not cook/bake the food; it only helps to defrost it within a short time.

Put the food to be defrosted on the wire rack that you will place on the centre rack support. To collect the water that accumulates due to the melting ice, insert an oven tray onto a lower rack. This function is perfect for finishing off the defrosting process for frozen food that has been in the refrigerator from the evening before and may not be completely thawed out.

### Conventional Cooking Function



The Conventional function allows heat to radiate evenly from the lower and upper elements into the oven ensuring even cooking of both sides of the food. Adjust the function control so it indicates the conventional Cooking function symbol. Adjust the thermostat control knob of your oven to a temperature recommended on the cooking table for the cooking operation you wish to perform. Preheating of the oven for about 10 minutes is recommended. Place food in a suitable container, then place into oven and cook for the recommended time. This function is preferred for making cakes (cupcakes, other cakes and sponges), biscuits, pastry, baked pasta (e.g. lasagne), casseroles and moist dishes, roasts and oven chips.

After cooking, turn off the oven function and temperature control knobs and set the timer to off. Take the cooked food out of the oven and place it in a safe heatproof surface. As the oven will be hot, work near with caution and keep children away from the cooling oven.

### Steam Clean Function



The Steam Clean function is used to help loosen oils and dried food from the inside of the cabinet. First remove all accessories (these can be cleaned in a sink). Place the tray at the bottom of the oven and pour 0.5L of water into the tray. Adjust the function control so it indicates the steam clean function symbol. Adjust the thermostat control knob of your oven to 70°C and allow to run for 30 minutes. After 30 minutes, turn off the oven function and temperature control knobs, set the timer to off and disconnect from the power source. Carefully open the door, remove the tray and clean the inside of the oven with a wet cloth (using warm water and dishwashing liquid on stubborn areas). Wash again with a clean damp cloth to remove any residue, and then replace all accessories. The interior should be allowed to cool until it is "touch safe" before attempting to clean, unless heat proof gloves are used.

### Upper Element Cooking Function



This function is used for grilling. Adjust the function control so it indicates the Upper Element cooking function symbol. Set the oven's thermostat control to the required temperature. After a preheating period of 10 minutes, put your food into the oven. For grilling, put the food on the grill rack and sit into the tray. Place the tray on the highest shelf. Placing the rack within the oven tray provided will ensure that any marinade, fat

**omega**

or oil dropping from the food will be collected. When grilling, the oven door must be closed.

This setting is ideal for toasting bread, cheese melts and melting cheese topped dishes or finishing off a dish to lightly brown on the surface. Also used for herb and garlic bread.

After cooking, turn off the oven function and temperature control knobs and cancel the timer program if in use. Take the cooked food out of the oven and place it on a safe heatproof surface. As the oven will be hot, work with caution and keep children away from the cooling oven.

### Maxi-Grill Function



This function is used for faster grilling and for grills with a lot of food. Adjust the function control knob so it indicates the Maxi-Grill function symbol. Set the oven's thermostat control knob to the required temperature. After a preheating period of 10 minutes, put your food into the oven. For grilling, put the food on the rack and sit over the tray. Place the rack on the highest shelf (4). Placing the rack above the oven tray provided will ensure that any marinade, fat or oil dropping from the food will be collected. When grilling, the oven door must be closed. On this function, all of the heating elements/coils of the grill operate.

The higher grill temperature and function is ideal for cooking and browning meat (such as lamb or pork chops and cutlets), chicken and seafood (such as fish fillets, cutlets, tuna steaks or Atlantic salmon). This setting is also good for browning fruit crumbles or crumb topped dishes.

After cooking, turn off the oven function, temperature control knobs and set the timer to off. Take the cooked food out of the oven and place it on a safe heatproof surface. As the oven will be hot, work near with caution and keep children away from the cooling oven.

### Maxi-Grill with Fan Function



This function will ensure complete, fast and all over grilling by working the fan, the grill and the upper heating element at the same time. Adjust the function control knob so it indicates the Maxi-Grill with Fan function symbol and adjust the oven timer to the recommended time for cooking. Set the oven's thermostat control to the required temperature. After a preheating period of 10 minutes, put your food into the oven. For grilling, put the food on the rack and sit over the tray. Place the rack on the highest shelf (4). Placing the rack above the oven tray will ensure that any marinade, fat or oil dropping from the food will be collected. When grilling, the oven door must be closed. The Maxi-grill with fan function is ideal for cooking food to achieve a crispy skin (such as chicken thigh or breast with the skin on) and lightly browning meat such as lamb and seafood.

After cooking, turn off the oven function and temperature control knobs and set the timer to off. Take the cooked food out of the oven and place it on a safe heatproof surface. As the oven will be hot, work near with caution and keep children away from the cooling oven.



# Operating Instructions

---

## Oven Function Controls

### Fan Assist Function



This is the function where the heat coming from the lower and upper heating elements is circulated into the oven by the fan motor and blade. Adjust the function control knob so it indicates the Fan Assist Function symbol and adjust the oven timer to the recommended time for cooking. Adjust the thermostat control knob to the temperature required on the cooking table for the Fan Assist Function and preheat oven for 10 minutes. Based on the conventional function, this combination of features increases the effectiveness of the thermal radiation of the heating elements through forced air circulation of the heat throughout the oven. This helps prevent food from burning on the surface, allowing the heat to penetrate into the food. Food baked using this function, such as pastry often brown faster than on the conventional function alone. After cooking, turn off the oven function and temperature control knobs and set the timer to off. Take the cooked food out of the oven and place it on a safe heatproof surface. As the oven will be hot, work near with caution and keep children away from the cooling oven.

### Fan Forced Function



This Fan Forced function uses the turbo heater (located in the back of the oven) to evenly disperse the heat in the oven. This function is suitable for cooking multiple dishes on various oven shelves. Adjust the function control knob so it indicates the Fan Forced function symbol. Adjust the thermostat control knob of your oven to a temperature recommended on the cooking table for the cooking operation you wish to perform.

Preheating of the oven for about 10 minutes is recommended. Place the food in a suitable container, then place into oven and cook for the required time.

If you are going to cook using two trays at the same time, while adjusting the cooking temperature, select the temperature that is the lowest among the levels suitable for your food of choice. Cooking with two trays requires additional cooking time compared to cooking with one tray. Usually, the food on each tray does not finish at the same time so you may need to take the tray of cooked food out of the oven, and continue the cooking operation for the remaining tray. After cooking, turn off the oven function and temperature control knobs and set the timer to off. Take the cooked food out of the oven and place it on a safe heatproof surface. As the oven will be hot, work near with caution and keep children away from the cooling oven

# Operating Instructions

## ACCESSORIES

It is recommended that you use the containers indicated depending on the food you will cook in your oven. You can also use glass containers, cake pans and special oven trays suitable for use in your oven (available in kitchenware shops). Pay attention to the information given by the supplier for use of this cookware. The information given below should be implemented for enameled containers.

If the food to be cooked does not completely cover the oven tray, if the food is taken out of the deep-freezer or if the tray is used to collect the dripping juices of the foods during the grill operation, deformation might be observed on the tray over time due to high temperatures forming during the cooking/baking operation. This is a normal, physical state that results during the heat transfer. Do not leave a glass tray or container in a cold environment immediately after cooking in them. Do not place them on cold and wet surfaces. Ensure that they slowly cool off by placing them on a dry piece of cloth or wooden board, otherwise, the glass tray or container might break. If you are going to use your oven to grill, we recommend using the grill rack with the tray on a position below. This way, splattering and dripping oils will not make the oven interior dirty. To make cleaning easier, add some water into this tray. In a grilling operation, use the shelf in position 4.

### WIRE GRIDS AND TRAYS

Each wire grid and tray comes with a built-in safety feature to help minimise them being accidentally pulled fully out. This comes in the way as a “step”, positioned partway in from the rear of the wire rack or tray.

To fit them into the oven, push the wire grid or tray part way into the oven until the step “catches”, then angle the part over the step & fully insert. To remove, repeat the process in reverse.

**WARNING:** Accessible parts may become hot when the grill is in use. Children should be kept away.

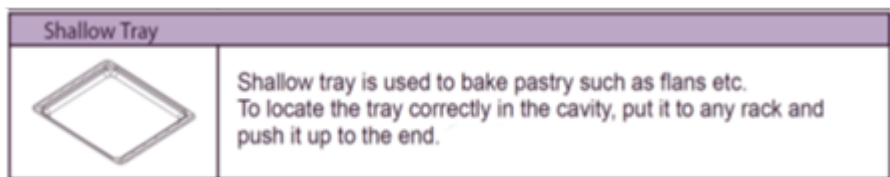
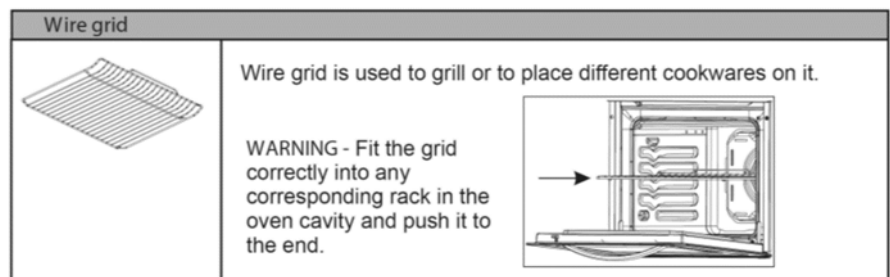

## Cleaning and Maintenance

---



**NOTE:** Cleaning and maintenance operations must only be carried out when the oven is cool.

The appliance should be disconnected from the power outlet or turned off at your isolation switch before commencing any cleaning process.

### Cleaning the oven exterior:

Before starting to clean your oven, be sure that all control buttons are off and your appliance has cooled. Unplug the appliance.

Do not use cleaning materials containing particles that might scratch the enamelled and painted parts of your oven. Use cream cleaners or liquid cleaners, which do not contain particles. As these cleaners may damage the surfaces, do not use caustic creams, abrasive cleaning powders, rough wire wool or hard tools. In the event of any excess liquids spilling over your oven surface during cleaning, clean up immediately so as to prevent possible damage to the enamel or metal surface. Do not use steam cleaners for cleaning the oven.

### Cleaning the interior of the oven:

Make sure to unplug the oven before starting to clean it. You will obtain best results if you clean the oven interior while the oven is slightly warm (the oven should not be operating). Remove the side wire racks first. Wipe your oven with a soft piece of cloth (e.g. dish cloth) dampened with warm soapy water after each use, rinse cloth in warm water then wipe oven again and finish by wiping with a dry cloth. It is also recommended to wipe clean the oven door and rubber seal. For a complete cleaning process, use dry and powder type oven cleaners, following the oven cleaning product's instructions.

### OVEN LAMP REPLACEMENT

- The appliance must first be disconnected from the power outlet or turned off at your isolation switch.
- Unscrew the glass cover attached to the lamp holder; anti-clockwise.
- Pull out the lamp and replace it with another high-temperature lamp with the following  
Type: E14  
Voltage: AC220V-240V  
Wattage: 15W Temperature rating: 300°C
- Remount the glass cover and reconnect the appliance to the power supply

**NOTE:** Should you experience any difficulty please contact your nearest after-sales service centre.

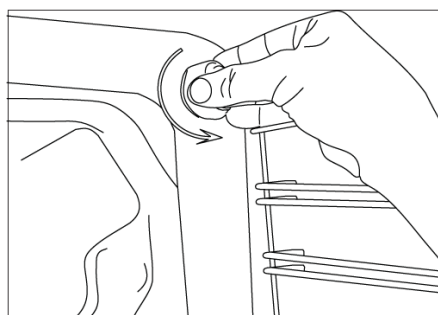

## Troubleshooting

---

### **If the oven does not operate:**

- The oven may be unplugged from the power source or switched off at the power source.
- The household fuse has blown or household power supply is off.
- The Timer (if available) may not set correctly.

### **If the oven does not heat:**

- The heat may not be set correctly with the oven's temperature setting.

### **If the interior lighting lamp does not light:**

- The lamps are defective. If they are defective, you can change them following the instructions within this manual.

### **Cooking (if lower-upper part does not cook equally):**

- Control the shelf locations, cooking period and heat values according to the manual.

### **Unit smoking when first used:**

- This is a result of protective oils being removed and is to be expected with a first use.

If you have any further problems with your product, please call your Authorised Service Centre.

## Warranty

### WARRANTY TERMS AND CONDITIONS OVENS

This document sets out the terms and conditions of the product warranties for Residentia Group Appliances. It is an important document. Please keep it with your proof of purchase documents in a safe place for future reference should you require service for your Appliance.

#### 1. IN THIS WARRANTY

- (a) 'acceptable quality' as referred to in clause 10 of this warranty has the same meaning referred to in the ACL;
  - (b) 'ACL' means Trade Practices Amendment (Australian Consumer Law) Act (No.2) 2010;
  - (c) 'Appliance' means any Residentia Group product purchased by you accompanied by this document;
  - (d) 'ASR' means Residentia Group authorised service representative;
  - (e) 'Residentia Group' means Residentia Group Pty Ltd of 165 Barkly Ave, Burnley VIC 3121, ACN 600 546 656 in respect of Appliances purchased in Australia;
  - (f) 'major failure' as referred to in clause 10 of this warranty has the same meaning referred to in the ACL and includes a situation when an Appliance cannot be repaired or it is uneconomic for Residentia Group, at its discretion, to repair an Appliance during the Warranty Period;
  - (g) 'Warranty Period' means:
    - (i) where the Appliance is used for personal, domestic or household use (i.e. normal single family use) as set out in the instruction manual, the Appliance is warranted against manufacturing defects for 24 months, following the date of original purchase of the Appliance;
  - (h) 'you' means the purchaser of the Appliance not having purchased the Appliance for re-sale, and 'your' has a corresponding meaning.
2. This warranty only applies to Appliances purchased and used in Australia and is in addition to (and does not exclude, restrict, or modify in any way) any non-excludable statutory warranties in Australia.

3. During the Warranty Period Residentia Group or its ASR will, at no extra charge if your Appliance is readily accessible for service, without special equipment and subject to these terms and conditions, repair or replace any parts which it considers to be defective. Residentia Group or its ASR may use remanufactured parts to repair your Appliance. You agree that any replaced Appliances or parts become the property of Residentia Group. This warranty does not apply to light globes, batteries, filters, seals or similar perishable parts.
4. Parts and Appliances not supplied by Residentia Group are not covered by this warranty.
5. You will bear the cost of transportation, travel and delivery of the Appliance to and from Residentia Group or its ASR. If you reside outside of the service area, you will bear the cost of:
  - (a) travel of an authorised representative;
  - (b) transportation and delivery of the Appliance to and from Residentia Group or its ASR, in all instances, unless the Appliance is transported by Residentia Group or its ASR, the Appliance is transported at the owner's cost and risk while in transit to and from Residentia Group or its ASR.
6. Proof of purchase is required before you can make a claim under this warranty.
7. You may not make a claim under this warranty unless the defect claimed is due to faulty or defective parts or workmanship. Residentia Group is not liable in the following situations (which are not exhaustive):
  - (a) the Appliance is damaged by:
    - (i) accident
    - (ii) misuse or abuse, including failure to properly maintain or service
    - (iii) normal wear and tear
    - (iv) power surges, electrical storm damage or incorrect power supply
    - (v) incomplete or improper installation
    - (vi) incorrect, improper or inappropriate operation
    - (vii) insect or vermin infestation
    - (viii) failure to comply with any additional instructions supplied with the Appliance;

— THIS WARRANTY IS VALID IN AUSTRALIA ONLY —

## Warranty

---

- (b) the Appliance is modified without authority from Residentia Group in writing;
  - (c) the Appliance's serial number or warranty seal has been removed or defaced;
  - (d) the Appliance was serviced or repaired by anyone other than Residentia Group, an authorised repairer or ASR.
8. This warranty, the contract to which it relates and the relationship between you and Residentia Group are governed by the law applicable where the Appliance was purchased.
9. To the extent permitted by law, Residentia Group excludes all warranties and liabilities (other than as contained in this document) including liability for any loss or damage whether direct or indirect arising from your purchase, use or non use of the Appliance.
10. For Appliances and services provided by Residentia Group in Australia, the Appliances come with a guarantee by Residentia Group that cannot be excluded under the Australian Consumer Law. You are entitled to a replacement or refund for a major failure and for compensation for any other reasonably foreseeable loss or damage. You are also entitled to have the Appliance repaired or replaced if the Appliance fails to be of acceptable quality and the failure does not amount to a major failure. The benefits to you given by this warranty are in addition to your other rights and remedies under a law in relation to the Appliances or services to which the warranty relates.
11. At all times during the Warranty Period, Residentia Group shall, at its discretion, determine whether repair, replacement or refund will apply if an Appliance has a valid warranty claim applicable to it.
12. Missing parts are not covered by warranty. Residentia Group reserves the right to assess each request for missing parts in a case by case basis. Any parts that are not reported missing in the first week after purchase will not provide free of charge.
13. To enquire about claiming under this warranty, please follow these steps:
- (a) carefully check the operating instructions, user manual and the terms of this warranty;
  - (b) have the model and serial number of the Appliance available;
  - (c) have the proof of purchase (e.g. an invoice) available;
  - (d) telephone the numbers shown below.
14. You accept that if you make a warranty claim, Residentia Group and its ASR may exchange information in relation to you to enable Residentia Group to meet its obligations under this warranty.

### IMPORTANT

Before calling for service, please ensure that the steps in point 13 have been followed.

### CONTACT SERVICE

→ Service: 1300 11 HELP (4357)

---

The Australian Consumer Law requires the inclusion of the following statement with this warranty:

Our goods come with guarantees that cannot be excluded under the Australian Consumer Law. You are entitled to a replacement or refund for a major failure and for compensation for any other reasonably foreseeable loss or damage. You are also entitled to have the goods repaired or replaced if the goods fail to be of acceptable quality and the failure does not amount to a major failure.

— THIS WARRANTY IS VALID IN AUSTRALIA ONLY —



