

Front Load Washing Machine, 8kg Capacity

AESTHETICS

White Finish with Black Control Panel

Tinted Black Glass Door

Remaining Time Display

Dial & Touch Control

White LED Display

FUNCTIONALITY

Wash Capacity: 8kg

15 x Washing Programs

Custom 'Personalised' Program

Steam Shield: Clean & Sterilise

Stain Solve: Targeting 5 Stain Types

Speed Wash & Adjustable Temperature

24hr Delay Start & Reload Options

Auto Weighing

Inverter Motor

1400RPM Spin Speed

PROGRAMS

1. Personalised

9. Quick 15'

2. Cotton

10. Steam Shield

3. Synthetic

11. Cotton ECO

4. Mix

12. 20°C

5. Baby

13. Wool

6. Sportswear

14. Spin Only

7. Denim

15. Drum Clean

8. Quick 45'

CONSUMPTION

Energy Rating (MEPS) 3.5 Stars

Water Rating (WELS) 4.5 Stars

Standard Cleaning Cycle ECO Wash

Energy Consumption 238 kWh/year

Water Consumption 68L per Wash

SAFETY

Child Lock Safety

Adjustable Feet

INSTALLATION

Freestanding Installation

SIZE W/D/H (MM)

Packaged: 650 x 555 x 850

Physical: 595 x 540 x 850

WEIGHT (KG)

Net: 63

Gross: 66

POWER REQUIREMENTS

Power Connection 10 Amp, Plug

Rated Voltage 220-240V~

Rated Frequency 50Hz

Rated Power 1950W

ADDITIONAL DETAILS

Water Pressure 0.05MPa-1MPa

Barcode 9349260096257

Warranty 3 Years

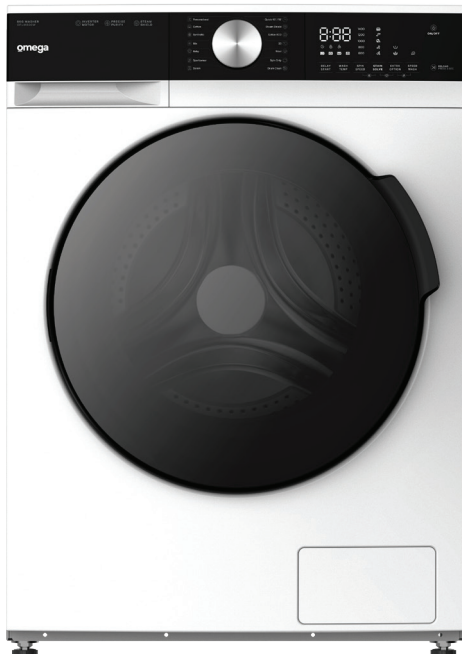

FRONT VIEW

Note: Please refer to the user manual for detailed installation and operation instructions, along with how to care & maintain your appliance.

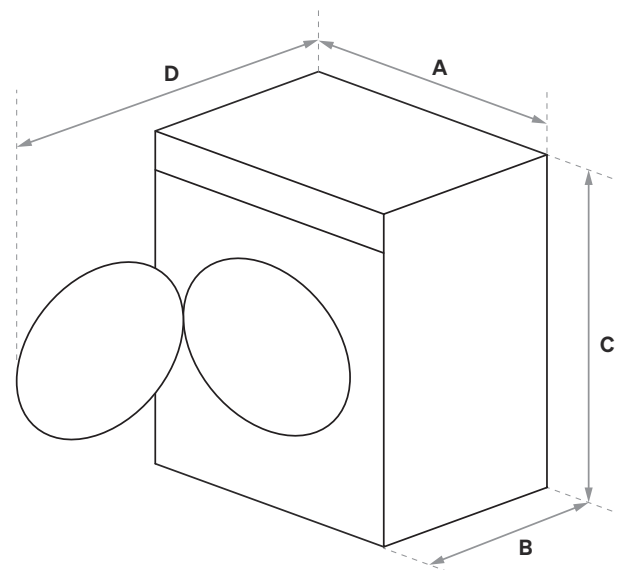

DIMENSIONS (MM)

A 595 C 850

B 540 D 985